



LUCAS

GENERAL CONTRACTING CORP.

SAFETY MANUAL (IIPP)

1111 Quail Street
Newport Beach, CA 92660
949/474.0221

Table of Contents

SECTION I	4
ILLNESS AND INJURY PREVENTION PLAN (IIPP).....	4
INDUSTRY BEST PRACTICES.....	5
RESPONSIBILITIES & DUTIES.....	6
SAFETY COMMUNICATION.....	8
DISCIPLINARY POLICY.....	9
HAZARD ASSESSMENT.....	10
HAZARD CORRECTION.....	10
ACCIDENT INVESTIGATION.....	11
SAFETY TRAINING.....	14
RECORDKEEPING.....	15
SECTION II	16
POLICIES AND PROCEDURES.....	16
CODE OF SAFE PRACTICES - FIELD.....	16
CODE OF SAFE PRACTICES – PROJECT SITE.....	19
CODE OF SAFE PRACTICES - OFFICE.....	20
EMERGENCY ACTION PLAN.....	22
FIRE SAFETY PROCEDURES.....	23
SUBSTANCE ABUSE POLICY.....	24
REQUIRED POSTINGS.....	27
VIOLENCE IN THE WORKPLACE.....	28
SUBCONTRACTOR SAFETY PROGRAM.....	29
SECTION III	32
HAZARD CONTROL.....	32
ACCESS & EGRESS.....	32
COMPRESSED GAS CYLINDERS.....	35
CONFINED SPACE ENTRY.....	35
CRANES.....	35
ELECTRICAL SAFETY.....	37
EQUIPMENT SAFETY.....	38
EXCAVATING AND TRENCHING OPERATIONS.....	38
FALL PROTECTION POLICY.....	39
HAZARDS ASSOCIATED WITH REINFORCING STEEL.....	42
HAZARDS ASSOCIATED WITH STRUCTURAL STEEL ERECTION.....	45
HEARING CONSERVATION PROGRAM.....	47
HEAT ILLNESS PREVENTION.....	48
HOUSEKEEPING.....	54
LOCK-OUT/TAG-OUT.....	55
PERSONAL PROTECTIVE EQUIPMENT.....	59
POST TENSIONING.....	60
POWERED INDUSTRIAL TRUCK PROGRAM.....	62
RESPIRATORY PROTECTION PROGRAM.....	65

RIGGING.....	74
WELDING AND CUTTING SAFETY.....	81
SECTION IV.....	83
PRE-PLANNING POLICIES.....	83
COLUMN & WALL ERECTION POLICY.....	83
JOB SAFETY ANALYSIS.....	86
SECTION V.....	87
OCCUPATIONAL HEALTH.....	87
BLOODBORNE PATHOGEN EXPOSURE CONTROL PLAN.....	87
FIRST AID PROGRAM.....	88
HAZARD COMMUNICATION PROGRAM.....	90
SECTION VI.....	93
APPENDICES.....	93
NOTICE OF VIOLATION.....	94
NEAR – MISS REPORT.....	95
REPORT OF ACCIDENT – PERSONAL INJURY.....	96
MEDICAL TREATMENT WAIVER.....	98
HEPATITIS B VACCINATION CONSENT/WAIVER FORM.....	99
LIABILITY REPORT.....	100
REPORT OF PROPERTY DAMAGE.....	101
AUTO ACCIDENT REPORT.....	102
ACCIDENT REPORTING – OSHA CONTACT INFORMATION.....	104

SECTION I

ILLNESS AND INJURY PREVENTION PLAN (IIPP)

INTRODUCTION

This manual establishes policies and identifies procedures that provide a safe and healthful working environment for all employees. This manual applies to all work performed by Lucas General Contracting employees and is only superseded by a more stringent standard.

OBJECTIVE

1. To provide guidelines for implementing a safety plan that will direct safety and health programs and to maintain compliance with federal, state, and/or local statutory requirements or regulations.
2. To minimize occupational injury and illnesses, equipment and property damage, and 3rd party bodily injury.
3. To establish responsibility and accountability for the safety program.
4. To define Best Practices as identified by the industry or LGC experience.

This manual is intended to list some of the policies, procedures, and practices of Lucas General Contracting and is subject to change, revision, or revocation at any time without notice. It is not to be construed as an employment contract or a guarantee of employment.

STATEMENT OF POLICY

It is the policy of Lucas General Contracting Corp. (“LGC”) that the first consideration in the performance of work shall be the safety of employees and the public. All effective methods, procedures and equipment necessary to achieve this end will be utilized.

Our safety program is based on the fact that accidents do not simply happen – they are caused. Only through the determined elimination of the cause of accidents can we reduce their frequency. LGC firmly believes that all accidents can be prevented.

The key to Accident Prevention is a safety culture where each employee accepts his/her responsibility to help in the prevention of accidents. LGC challenges employees with taking responsibility for their personal safety as well as the safety of their co-workers.

To carry out this policy, the Company, including all Supervisors, accepts the responsibilities outlined in the LGC safety manual. It is your responsibility to read, understand, follow and enforce this policy.

Rob Plavajka
**Vice President Field Operations/
Director of Safety**

Robert Mahony
Chief Financial Officer

INDUSTRY BEST PRACTICES

Pro-active safety management is not one specialist's opinion of what looks unsafe. It's the combined effort of workers identifying the specific hazards, safety professionals analyzing the probability or occurrence, and management and employees deciding on appropriate courses of action.

Traditional Safety Approaches

The initial safety approaches in the U.S, were implemented as a direct result of the OSHA Act, and are now referred to as "traditional." Many of these are based on efforts to improve engineering and work environments, including authoritarian management models, the formalizing of rules and procedures, and the policing of employees to enforce the rules. These traditional approaches to managing safety relied heavily on triggers such as safety training, safety meetings, rules, policies, procedures, controls, OSHA standards, etc. They seldom included evaluation or follow-up to training and the major consequence of non-compliance was punishment.

OSHA Minimum Standards

The OSHA standards provide minimal requirements, and not a viable method of realistic safety practices that can be utilized in a work environment. The goal of any safety or loss control effort is to provide guidance on how to safely accomplish a task with a variety of unknown circumstances. It is therefore inconsistent to believe that any workplace can be protected by simply operating according to minimal standards of formalized rules and procedures.

Industry Best Practices

Operation by best industry practices is defined as providing the guidance, knowledge and direction necessary to plan and execute any task, at any point in time with known and unknown circumstances. Although the most common and severe accidents were reduced, the results from traditional methods began to plateau and the safety industry identified more effective methods.

Best industry practice was identified as the preferred approach. Best industry practices provide for pre-planning, proper execution and contingency possibilities as a method of operational execution. It is through individual and collective knowledge of hazards and effective communication that true hazard abatement occurs.

LGC's best management practices are performance based with a primary focus on eliminating all incidents/injuries while improving efficiency. Performance management provides an ideal basis for identifying worker behavior which cause accidents, addressing all the major factors which influence behaviors, and providing continuous improvement. Our performance-based approach to safety combines many of the best features of traditional and behavioral systems. LGC does not advocate standardized approaches. Instead, LGC relies on the professional competence of our supervisors in order to accurately evaluate all conditions and provide cost effective recommendations.

RESPONSIBILITIES & DUTIES

SAFETY DIRECTOR'S RESPONSIBILITIES

The Director of Safety is responsible for the overall risk control of the construction business. Responsibilities include managing and evaluating the Company-wide Safety Program, Risk Management and Human Resources on the elimination of accidents and return to work policies.

- Continually update the Company Safety Manual.
- Provide safety related material for pre-bid and pre-construction meetings.
- Provide JSA/JHA reports when required.
- Provide onsite, (field) inspections in support of the Superintendents.
- Ensure the adequate training of all Superintendents and New Hires.
- Manage all Cal/OSHA inspections and mitigate any penalties or fines assessed.
- Maintain full knowledge and understanding of the laws, regulations and industry trends impacting LGC.
- Investigate accidents and incidents and implement changes to prevent reoccurrence.

SUPERINTENDENT'S RESPONSIBILITIES

The Superintendent is responsible for administering the Company Safety Program under the direction of the Director of Safety. Responsibilities include communicating policies and procedures along with legal Federal, State & Local regulations as they apply to the employees of LGC.

- Maintain the Company Safety Manual(s) and insure availability on the project site.
- Maintain the Safety forms and documents that are used in conjunction with the Company Safety Program.
- Maintain the tailgates used by the field and insure their availability on the jobsite.
- Provide guidance & assistance to employees in completing JSA/JHA forms
- Provide onsite, inspections in support of the Subcontractors.
- Ensure all facilities remain up to date and in compliance with EPA, AQMD, NPDES, SWPPS & all other environmental agencies as they apply to the business of LGC.
- Lead in the investigation of all accidents & incidents and ensure corrective actions are implemented to eliminate future occurrences.
- Enforcement of the Injury and Illness Prevention Program
- Provide full support for the Director of Safety and Insurance Representatives
- Liaison for communication between the LGC, Director of Safety and Subcontractor Field Supervision.
- Make certain all federal, state, and local laws or regulations are complied with.
- Collaborate with the Director of Safety on Project Pre-Planning.
- Monitor accidents and incidents on projects under their supervision.
- Maintain and track safety equipment and materials for all projects under their supervision.
- Superintendents are responsible for relaying the information gained in Safety Committee meetings to Subcontractors' Foremen and Employees in their respective trade.

General Safety

- Take responsibility for their workers safety above all else.
- Instruct employees under their supervision in safe work practices and work methods at the time assignments or hire date. (Code of Safe Practices)
- Ensure an adequate supply of personal protective equipment and tools for the tasks assigned.
- Hold weekly Safety Tailgate meetings, complete with documentation.
- Conduct weekly safety inspections of the jobsite, complete with documentation.

Accident Reporting

- Promptly report all accidents, incidents and near misses involving worker injury, 3rd party injury, vehicle accidents, property damage, theft or vandalism
 - Ensure injured workers receive prompt first aid or medical attention.
 - Provide all accident reports and witness statements to the designated LGC Director of Safety within 24 hours.
 - Serious injury, illness or a fatality must be reported within 8 hours to OSHA.
 - Cal-OSHA defines "Serious injury or illness" as: any injury or illness occurring in a place of employment or in connection with any employment which requires inpatient hospitalization for a period in excess of 24 hours for other than medical observation or in which an employee suffers a loss of any member of the body or suffers any serious degree of permanent disfigurement.
 - Federal OSHA and all other States reporting requirement: after the death of any employee from a work-related incident or the in-patient hospitalization of three or more employees as a result of a work-related incident
- * For specific directions on how to report serious injury, illness or a fatality, see the Appendix

Compliance

- Insist on compliance with the LGC Safety Program, and all LGC safety policies within the program.
- Document jobsite and shop self inspections on a weekly basis, in the field, fall protection equipment on a weekly basis.
- Notify the Director of Safety of hazardous conditions.
- Notify Subcontractor of any hazardous conditions which are not within the direct control of Lucas General Contracting and document the notification.
- Not allow employees to work in unsafe or hazardous conditions. **Stop work if necessary & contact Director of Safety.**
- Set a good example for Subcontractors and represent Lucas General Contracting in the most professional manner possible.

Employees

Employees shall work in a safe manner at all times and follow the Company Safety Policies and Procedures outlined in this manual as well as all applicable Federal & State OSHA Regulations.

Every employee shall:

- Comply with the LGC Safety Program, and all LGC safety policies within the program.
- Wear and use the PPE required by their job function.
- Only operate tools, machinery & equipment they have been trained and authorized to operate.
- Report any unsafe or unhealthy work situation immediately to their supervisor.

SAFETY COMMUNICATION

LGC Communication to Employee:

Communication of expectations, policies and procedures will be through the receipt and acknowledgement of the written Safety Program and any orientation provided.

Monthly Safety Committee meetings are held with all Field staff. Superintendents are responsible for relaying the information gained in these meetings to Subcontractor Foremen.

Additionally, information is posted on bulletin boards in each construction office for all employees and Subcontractors. Memos and urgent safety information is provided with paychecks.

Task specific training will be provided on an as needed basis with documentation provided to the Director of Safety. Additional task specific training and foreman training requirements may be required by the Hazard Control sections of this manual.

Employee communication to LGC:

Any employee who identifies an unsafe condition is required to contact their Supervisor or Manager as they are the primary safety resource. If an employee wishes to report an unsafe condition or an activity that is likely to result in a loss to LGC, they may do so anonymously by leaving a message at the number provided below or contacting the Director of Safety using the number provided below.

Anonymous safety and health reports shall be investigated, and if found valid, shall receive immediate appropriate corrective action.

**To Anonymously Report an unsafe condition or practice,
call: 949-474-0221**

**To contact the Director of Safety, you may
call: 949-474-0221
Fax: 949-474-3097**

E-Mail at: rplavajka@lucascompanies.net

DISCIPLINARY POLICY

ACCOUNTABILITY

Violation(s) of our company's Safety Standards will be handled as follows:

FIRST VIOLATION: A written reprimand describing the specific safety rule violated will be issued to the employee who violated the safety rule. A meeting and discussion will be held with the employee by the direct supervisor and/or Director of Safety to ensure understanding of the violation. A copy of the reprimand will be maintained on file at LGC Newport Beach office.

SECOND VIOLATION: A written reprimand describing the specific safety rule violated will be issued to the employee who violated the safety rule. A meeting and discussion will be held with the employee by the direct supervisor, Superintendent and/or Director of Safety to ensure understanding of the violation and the seriousness of the second (2nd) offense. A three (3) day suspension from work without pay will accompany a second violation. A copy of the reprimand and meeting will be maintained on file with the Company. A letter may be sent to the employee's home describing the seriousness of safety violations in direct relation to employment at Lucas General Contracting.

THIRD VIOLATION: A written report describing the safety rule violated will be issued to the employee who violated the safety rule and a meeting and discussion will be held with the employee by the direct supervisor, and/or Director of Safety. Termination of employment from the Company will occur immediately after such meeting unless it's determined that a third (3rd) violation did not occur.

Other:

1. Serious and/or willful violations of policy may result in termination on the first offense
2. Repeat offenses which result in an injury or incident may result in termination on the first offense.
3. All written reprimands must be signed by the Director of Safety.
4. Prior to terminating an employee for safety violations, a meeting should occur between the supervisor and Director of Safety.

***Fall Protection violations will result in the following action:**

- **First offense will result in 3 days suspension without pay**
- **Second offense will result in termination.**

HAZARD ASSESSMENT

INTRODUCTION

Safety inspections are an important Company management tool intended to identify and correct hazards on the jobsite. Inspections are to be a fact-finding process, not faultfinding. Locating and correcting hazards in a timely manner with management review and follow-up is Lucas General Contracting policy.

Inspections are to be a visible process of evaluating and documenting hazards. This process does not replace continual identification and correction of hazards and poor safety practices. All employees are encouraged to identify and correct unsafe conditions and practices that may exist in the workplace.

ACCOUNTABILITY

1. Superintendents shall conduct weekly jobsite safety inspections to discover new and/or unrecognized hazards.
2. Superintendents shall conduct and document safety inspections at regular intervals.
3. Director of Safety shall conduct jobsite safety inspection daily for all job sites visited.
4. Additional hazard assessments and safety inspections shall be conducted by the Director of Safety, and other members of the Lucas General Contracting Management Staff whenever deemed appropriate.

All inspections shall be copied to the Director of Safety for discussion at monthly safety committee meetings and for ensuring the corrective items have been corrected in a timely manner.

HAZARD CORRECTION

INTRODUCTION

It is the intention of Lucas General Contracting to eliminate all hazards and unsafe practices immediately and upon discovery. All hazards discovered by the inspection process, employee suggestions, or any other means will be mitigated in a timely manner. Some corrective actions may require more time to abate; priority will be given to severe and imminent hazards (those which pose an immediate danger causing serious bodily harm).

All affected employees will be informed of the hazard. While corrective action is being taken, precautions will be taken to protect or remove employees from exposure to the hazard. If the hazard is determined to be of imminent danger, employees may not enter the imminent hazard area. Only those employees expected to correct the imminent hazard may enter the area after being given training to mitigate the hazard.

All hazards, whether identified, newly discovered, observed, or imminent danger will be documented using the appropriate form (inspection form, accident investigation form, near-miss form). The person designated to take the corrective action will sign and date the documentation with the date of corrective action completion.

ACCIDENT INVESTIGATION

INTRODUCTION

Accident Investigation and Reporting is a critical element of accident prevention. If we experience an accident and do not identify what happened, we see the recurrence of similar accidents in the future. In addition to accidents involving employee injuries, the foreman shall complete a Report on any incident involving an automobile, property damage, 3rd party damage or bodily injury. All accidents reports shall be completed within 24 hours.

ACCOUNTABILITY

The LGC Superintendent is responsible for ensuring that an accurate accident investigation is completed and the LGC Accident Report is provided to your Director of Safety within 24 hours. The Superintendent must use the following best practices:

ACCIDENT INVESTIGATION & REPORTING BEST PRACTICES

1. Transport/Treat the injured worker. Evaluate the extent of the injury to determine if first aid can be administered. If not, ensure that the employee is transported to a medical clinic or hospital based on the severity of the injury.
2. If ambulance transportation is required, a LGC subcontractor designated by the Superintendent should accompany the injured worker.
3. Direct the injured worker to the designated Medical Clinic based on the project location.
4. Contact your Director of Safety immediately after taking care of the immediate needs of the injured employee: (949) 474-0221 (office) or (949) 474-3097 (fax). Inform the Director of Safety of the basic details of the injury including injured employee's name, jobsite, what occurred, and any corrective actions.
5. Secure the scene and ensure all workers are accounted for and unharmed.
6. Secure any obvious hazardous conditions. Secure any potential evidence (i.e. rigging, fall protection, etc) and maintain in your possession until it can be safely delivered to the Director of Safety.
7. Take photographs of the entire area from as many angles as possible.
8. Do not discuss the accident with media, police or OSHA. Direct those parties to the Director of Safety or CFO (OSHA, Police, Media)
9. An Accident Investigation Report will be completed on all accidents and near miss incidents. (near miss - any incident not resulting in an injury or property damage, but, having the potential to result in injury or damage). This report is provided to the Director of Safety.
10. Witness statements should be obtained from actual witnesses of the accident. They should indicate what they visually witnessed.
11. The Accident report will be completed and turned into the Director of Safety within 24 hours of the incident.
12. The Superintendent will notify the LGC Director of Safety immediately of any injuries involving: Death, Serious injury including injured employees transported by ambulance, potential overnight stay in the hospital, amputation including partial amputation, unconsciousness, heart attack, two or more employees injured in the same accident. If unavailable, the Superintendent shall notify the CFO.
13. The Director of Safety will review the investigation report with the Superintendent & affected employee(s) to discuss recommended corrective action.

ACCIDENT INVESTIGATION/REPORTING

Employees are our most important assets, helping us build complex projects such as Apartment buildings, parking structures, etc. We value healthy, hardworking employees who, through their efforts, contribute everyday to the bottom line. In the midst of working hard, we realize that accidents may happen, which might result in either injury or property damage. When this happens...

1. If you are not sure if an accident should be reported, play it safe and report it.
2. Report any accident or incident including a “near miss” to your Supervisor immediately.
3. If the accident results in injury, the Supervisor will direct the injured worker to a local Medical Clinic.
4. No employee will be punished or reprimanded for reporting an accident.
5. Delayed or non-reporting of an accident may result in denial of medical care or benefits.
6. If you are involved in an accident, cooperate with all parties investigating on behalf of LGC and secure whatever evidence available.
7. The Superintendent at the jobsite will complete an Accident Report Form on every accident. This includes employee injuries, near misses, automobile accidents, property damage, and 3rd party property damage or bodily injury.
8. Safety is EVERY employee’s responsibility. Report all unsafe conditions or safety concerns to your Supervisor immediately.
9. **DO NOT** work in an environment that you know is unsafe. Take personal responsibility for your safety!

Injured Employees: You are required to submit all work releases to the Company after each Medical Appointment.

IT IS BETTER TO REPORT, THAN NOT TO REPORT – BE SAFE, NOT SORRY.

WHEN TO REPORT A WORKERS' COMPENSATION CLAIM

A worker's compensation claim must be filed whenever an injured worker receives medical attention beyond First Aid Treatment.

An "incident/accident" report shall be completed within 24 hours when:

1. An employee suffers a work related injury or illness which does not require immediate medical attention.
2. An employee receives any sort of professional medical attention (e.g., doctor, nurse or first aid provider).

OSHA INSPECTIONS

1. Be sure the visitors really are OSHA representatives. Require them to show proper identification. If they don't, escort them off your site.
2. Request time, up to 1 hour, to contact your Superintendent and Director of Safety.
3. Be courteous and polite.
4. Ask why the OSHA inspectors have come to your site. Have they been called to investigate a specific situation?
5. Always keep a copy of your LGC safety program on site and readily available.
6. Walk with the OSHA inspectors during their tour of the site.
7. If you are not absolutely certain that every employee is working within OSHA standards, stop work while OSHA is on site, and have employees focus on cleaning up the site.
8. Duplicate all the information OSHA gathers. When the inspectors take photos, you take photos (the more the better, and from multiple angles, if possible). When the inspectors write something down, you write down the same thing. If OSHA talks to someone working on site, write down the questions, the answers and the name of the person.
9. Employees have the right to talk with OSHA representatives during the site inspection if they want to.
10. OSHA has the right to interview employees individually; however, employees may request that their Foreman or a company representative be present.
11. Employees have the right to have a representative (union representative or lawyer) present during the interview.
12. During the inspection, do not agree or disagree with the OSHA inspector.
13. Be honest. Give the best information you can. But answer only questions that you understand and that pertain to you. Answer only the questions asked, do not give additional information, volunteer additional information or expand into other topics.
14. If OSHA offers suggestions or points out unsafe acts as you are walking the job site, fix them immediately. It shows your good faith.

SAFETY TRAINING

INTRODUCTION

Lucas General Contracting understands the value of training our employees and empowering them to make the appropriate safety decisions. Superintendents are the front line defense against accidents and incidents on the job. LGC invests in training our employees above and beyond the years of experience they come to us with.

ACCOUNTABILITY

Superintendent

In addition to the required “Employee Safety Orientation”, the following courses are required in order to be a Superintendent at Lucas General Contracting:

- OSHA 10 Hour (Superintendents only) (In addition, refresher course may be required at the discretion of the Company)
- CPR & 1st Aid (Every 2 Years)
- Basic/Advance Rigging
- Fire Extinguisher (Every Year)
- Fall Protection (Every Year)
- Excavation Safety
- Scaffold User
- Compressed Gas Safety (Oxygen Acetylene)
- Conduct weekly site meetings
- Complete accident reports in accordance with the safety manual
- Conduct weekly jobsite safety inspections
- Maintain training documentation
- Implement site specific safety policies and procedures
- Demonstrate by example, proper safety behavior
- Ensure first aid supplies are adequate

Employees shall receive training prior to undertaking any task or job assignment. Training shall consist of the following:

- New Hire Safety Orientation (Code of Safe Practices, Company Safety Policy, Company Safety Manual)
- On-Line training such as OSHA 10 & 30 hr.

RECORDKEEPING

Recordkeeping

All training shall be recorded on appropriate forms showing the person trained, subject and date.

All tailgate training rosters and safety inspections conducted shall be kept in the Safety Manual.

All accident investigations shall be filed with the case file of the injured employee at the main office.

Inspection records shall be kept for up to ten (10) years.

- Copies of mandatory weekly safety meeting minutes.
- Copies of mandatory monthly safety inspections.
- Copies of reports/investigations regarding accidents or near-miss accidents occurring on the site for the duration of use plus 30 years.
- Employee medical records shall be retained for the duration of employment plus 30 years, Per the requirements and exceptions of General Industry Safety Order 3204 (d)(1)(A)(1), (2), (3), and 3204(d)(1)(B)(1), (2), (3), and 3204(c)(2).
- Material Safety Data Sheets (MSDS) for any hazardous materials used on the job site.
- Employee orientation sign off sheets, including those for subcontractors.
- Copies of any OSHA required documentation (e.g., 300 log, crane inspections, soil evaluations, training, etc.).

SECTION II

POLICIES AND PROCEDURES

CODE OF SAFE PRACTICES - FIELD

GENERAL

1. All persons shall follow these safe practices rules, render every possible aid to safe operations, and report all unsafe conditions or practices to Subcontractor's Foreman or LGC Superintendent.
2. All employees shall be given frequent accident prevention instructions. Instructions shall be given at least weekly.
3. When applicable, accident prevention instructions shall include specific instruction on the safe use, care and maintenance of fall protection equipment (i.e. fall arrest systems, positioning device systems, safety nets, etc.) used at the jobsite.
4. Anyone known to be under the influence of drugs or intoxicating substances which impair the employee's ability to safely perform the assigned duties shall not be allowed on the jobsite.
5. LGC employees are not authorized to enter manholes, underground vaults, chambers, tanks, silos, or other similar places that receive little ventilation, unless trained and authorized to enter.
6. LGC employees are not authorized to work outside of the capacity of their training and their professional designation.
7. Horseplay, scuffling, and other acts that tend to have an adverse influence on the safety or well-being of the employees shall be prohibited.
8. Work shall be well planned and supervised to prevent injuries in the handling of materials and in working together with equipment.
9. All injuries shall be reported promptly to the Foreman or Superintendent.

HOUSKEEPING

1. All offices and work areas shall be kept clean and organized.
2. Material storage areas and walkways on the construction site shall be maintained reasonably free of dangerous depressions, obstructions, and debris.
3. Flammable or hazardous wastes shall be placed in covered containers separate from the normal debris.
4. All waste shall be disposed of at intervals determined by the rate of accumulation and capacity of the job site container.

REINFORCING STEEL

1. All reinforcing steel extending up to 6' must be protected in an appropriate manner.
2. Form stakes and stakes used to support column braces must be protected.
3. Workers must be protected from a horizontal bar when it protrudes into an access way.
4. Workers are not allowed to work above 6' without approved fall protection devices.
5. Workers must use 100% tie off procedures when working above exposed rebar.
6. Work areas must be inspected daily to ensure that all rebar caps/troughs are in place prior to commencing work and when returning from a break.

SCAFFOLD SAFETY

1. Scaffolding shall be erected on a firm, solid and compacted base.
2. Guardrails shall be installed on all open sides of scaffolds more than 10 feet above the ground or floor.
3. Metal scaffolds shall be securely tied to the building or structure.
4. All working platforms must be fully planked and overlapped at least 12 inches.
5. Scaffolding must be inspected and tagged ready for use by a competent person prior to use.

LADDER SAFETY

1. The use of ladders with broken or missing rungs or steps, broken or split side rails, or other faulty or defective construction is prohibited.
2. Portable ladder feet shall be placed on a substantial base, and the area around the top and bottom of the ladder shall be kept clear.
3. Extension ladders shall be used at a 4:1 pitch.
4. Ladders shall not be used in a horizontal position as platforms, runways, or scaffolds.
5. Ladders shall not be placed in passageways, doorways, driveways, or any location where they may be displaced by activities being conducted on any other work, unless protected by barricades or guards.
6. The side rails shall extend not less than 36 inches above the landing.
7. Portable ladders in use shall be tied, blocked, or otherwise secured to prevent them from being displaced.
8. Always maintain a three point contact when climbing up or down ladders.
9. "A" Frame ladders shall only be used in the fully opened and locked position.

PERSONAL PROTECTIVE EQUIPMENT

1. Hardhats, boots, long pants and shirts with sleeves are required for all workers.
2. When cutting or welding the appropriate protective device(s) available shall be worn.
3. Positioning hooks must be in perfect working order with all the tags legible.
4. Fall Protection Harnesses must be inspected prior to use and at least quarterly thereafter.
5. Safety glasses are required at all times.

CRANE SAFETY

1. Only crane companies on the LGC approved Subcontractor/vendor list shall be used.
2. Cranes must be inspected prior to each use to ensure they are fit for operation.
3. Only qualified persons shall give signals to crane operators.
4. The swing radius of crane cab shall be protected.
5. Cranes shall not be left unattended with a load suspended.
6. No load shall be swung over personnel and no person shall work under suspended loads unless the load is effectively blocked to prevent it from falling.
7. Truck cranes shall have the outriggers firmly and securely set before attempting to lift a load.
8. On soft ground, "blocking" shall always be used under outrigger floats to prevent deflection or sinking.
9. Outriggers shall always be fully extended.
10. Crane Cabs must have a serviceable fire extinguisher in the cab.
11. Cranes must be level prior to lifting a load. An unlevelled crane could cause a side load on the boom.

POST TENSIONING SAFETY

1. Signs and/or barriers shall be erected to limit employee access to the post-tensioning area during Post Tensioning operations.
2. No employee shall be permitted to be behind the jack during tensioning operations.
3. Tensioning operations shall be under the immediate control of a person experienced in such operations.

4. Do not stand over, in front of, or behind the jack during stressing.
5. Watch the pressure gauge at all times. - Do not over stress the tendon.
6. Never use the tensioning machine for anything other than its intended use.
7. Do not wipe excess grease on forms, or other work surfaces, use rags and dispose of them properly.
8. Workers directly involved in stressing operations must wear safety glasses or goggles.

TRENCHING & EXCAVATION

1. Trench & Excavation egress must be provided within 25' from the workers.
2. Excavations with free standing water or water intrusion must have a method for extracting the water.
3. LGC personnel are not authorized to enter an excavation greater than 5' deep without a protective system in place. i.e. Shoring, Sloping, Benching, or Trench Boxes.

COMPRESSED GAS CYLINDERS

1. All compressed gas cylinders shall be secured at all times
2. Acetylene tanks must be stored and used in an upright position only.
3. Oxygen and Fuel shall be separated by at least 20' or a ½ hour rated fire wall.
4. Valve protection caps shall be kept on cylinders except when in use.
5. Always store compressed gas cylinders in a well-ventilated area protected from direct sunlight if possible.
6. Lifting Cylinders will only be accomplished in a cart or other secure method.
7. Torch cutting operations must have a serviceable 10 lb chemical fire extinguisher within 25' of point of operation.

COLUMN AND WALL ERECTION SAFETY

1. Prior to erecting walls & columns a Vertical Erection Plan, VEP, must be submitted to LGC safety department.
2. All vertical elements shall be properly supported to prevent collapse either through use of internal or external support(s). Prior to any employee climbing any vertical elements (e.g. walls or columns), the same shall be supported via the use of external supports such as guy wires or pipe braces.
3. A missing, defective or inappropriate pipe brace shall be brought to the attention of the jobsite Foreman immediately.
4. Always be aware of weather conditions. If conditions could cause a safety hazard, notify your Supervisor immediately

RIGGING

1. Know the safe working load of the equipment and tackle being used. NEVER exceed this limit.
2. Determine the weight of the load before rigging it.
3. Examine all hardware, equipment, tackle and slings before use. Destroy any defective components immediately!
4. If you think equipment or rigging is unsafe, do not use it and report the issue to your Subcontractor's Foreman or Supervisor.
5. Never carry out rigging or hoisting operations if weather creates a hazard to personnel, equipment, property or the public. No hoisting or crane usage is authorized when winds exceed 20 knots.
6. LGC is not authorized to conduct rigging and lifting operations whenever the temperature is below freezing (32 degrees F).
7. Rigging and lifting is not allowed within 20' of overhead power-lines.

STRUCTURAL STEEL ERECTION

1. A site specific erection plan shall be developed and all Subcontractors employees trained prior to the commencement of hoisting operations.
2. The Subcontractor's Foreman shall receive written notification of concrete strength prior to placing any structural members.
3. A qualified rigger shall inspect the rigging prior to each shift.
4. Structural stability shall be maintained at all times during the erection process.
5. There shall not be more than 8 stories between the erection floor and the upper most permanent floor, except where structural integrity is maintained as a result of the design.
6. At no time shall there be more than four floors or 48 ft., whichever is less, of unfinished bolting or welding above the foundation or uppermost permanently secured floor, except where structural integrity is maintained as a result of the design.
7. Roof & Floor holes and openings shall be covered, and covers shall be secured in place, and painted with high-visibility paint or marked with the word "Hole" or "Cover".
8. A steel joist or girder shall not be placed on any support structure unless such structure is stabilized.
9. Steel joists and girders shall not be used as anchorage points for a fall arrest system without written approval from a qualified person.
10. Construction loads shall not be placed on any structural steel framework unless such framework is safely bolted, welded or otherwise adequately secured.
11. Taglines shall be used on all hoisted loads that expose employees to the swing of the load.
12. Connectors shall be protected from fall hazards of more than 2 floors or 30' whichever is less.
13. Connectors must complete special training for hazards associated with connecting prior to being assigned the duties of a connector.
14. Whenever possible Connectors shall straddle the beam instead of walking along the top flange.
15. A minimum of 2 bolts for beams, wrench tight per connection prior to releasing crane hoist lines
16. All columns shall be anchored by a minimum of 4 anchor bolts.
17. Diagonal bracing shall be installed with a minimum of 1 bolt wrench tight.
18. All hoisting operations must be pre-planned.
19. Perimeter columns must extend 48" above finished floor.
20. Perimeter columns shall be fabricated with holes and/or other devices for safety cables.

CODE OF SAFE PRACTICES – PROJECT SITE

1. Workers shall report all unsafe conditions and equipment to the Site Superintendent immediately.
2. Workers shall immediately report all accidents, injuries and illnesses to the Site Superintendent.
3. Workers shall not operate any equipment that they are not authorized and trained to use.
4. Anyone known to be under the influence of intoxicating liquor or drugs shall not be allowed on the job while in that condition.
5. Horseplay, scuffling, or other acts that tend to adversely influence the safety or well-being of the employees are prohibited.
6. Means of egress shall be kept unblocked, well lighted and unlocked during work hours.
7. In the event of fire, evacuate.
8. Upon hearing a fire alarm, stop work and proceed to the nearest clear exit. Gather at the designated assembly area.
9. Exit doors must remain unlocked during business hours and comply with fire safety regulations.
10. Keep stairways clear of items that can be tripped over.
11. Areas under stairways that are egress routes should not be used to store combustibles.
12. Materials and equipment will not be stored against doors or exits, fire ladders or fire extinguisher stations.
13. Aisles must be kept clear at all times.
14. Work areas should be maintained in a neat, orderly manner. Throw trash and refuse into proper waste containers.

15. All spills shall be wiped up promptly.
16. Always use the correct lifting technique. Never attempt to lift or push an object that is too heavy (more than 60lbs). Seek help to move heavy objects.
17. Never stack material precariously on top of lockers, file cabinets or other high places.
18. When carrying objects, use caution in watching for and avoiding obstructions or loose material.
19. Do not stack material in an unstable manner.
20. Report exposed wiring and cords that are frayed or have deteriorated insulation so that they can be repaired promptly.
21. Never use a metal ladder where it could come in contact with energized parts of equipment, fixtures, or circuit conductors.
22. Maintain sufficient access and working space around all electrical equipment for ready and safe operations and maintenance.
23. Do not use any portable electrical equipment or tools that are not grounded or double insulated.
24. Plug all electrical equipment into appropriate wall receptacles, or into an extension of only one cord of similar size and capacity. Three-pronged plugs should be used to ensure continuity of ground.
25. All cords running into walk areas must be taped down or be covered by protectors to prevent tripping hazards.
26. Inspect motorized vehicles and other mechanized equipment daily or prior to use.
27. Shut off engine, set brakes and block wheels prior to loading or unloading vehicles.
28. Inspect pallets and their loads for integrity and stability before loading or moving.
29. Do not store compressed gas cylinders in areas that are exposed to heat sources, electric arcs or high temperatures lines.
30. Do not use compressed air for cleaning off clothing unless pressure is less than 10 psi.
31. Employees must wear head protection, eye protection, hearing protection and steel toe work boots at all times.
32. Goggles or face shields must be worn when grinding.
33. Do not use any faulty or worn hand tools.
34. Do not eat in areas where hazardous chemicals are present.
35. Store cleaning solvents and flammable liquids in flammable storage lockers.
36. Keep solutions that may be poisonous or are not intended for consumption in well-labeled containers.
37. Keep appliances such as coffeepots or microwave ovens in working order and inspect them for signs of wear, heat or frayed cords.
38. Fans used in work areas should be guarded, and guards must not allow fingers to be inserted through the mesh.

CODE OF SAFE PRACTICES – OFFICE

1. Employees shall report all unsafe conditions and equipment to the supervisor or Director of Safety.
2. Employees shall report immediately all accidents, injuries and illnesses to the supervisor or Director of Safety.
3. Means of egress shall be kept unblocked, well lighted and unlocked during work hours.
4. In the event of fire, evacuate.
5. Upon hearing a fire alarm, stop work and proceed to the nearest clear exit. Gather at the designated location.
6. Only workers trained for it may attempt to respond to a fire or other emergency.
7. Exit doors must comply with fire safety regulations during business hours.
8. Keep stairways clear of items that can be tripped over. Areas under stairways that are egress routes should not be used to store combustibles.
9. Materials and equipment will not be stored against doors or exits, fire ladders or fire extinguisher stations.
10. Keep aisles clear at all times.
11. Maintain work areas in a neat, orderly manner. Throw trash and refuse into containers.

12. Wipe up all spills promptly.
13. Store files and supplies in a manner that prevents damage to supplies or injury to personnel when they are moved. Store heaviest items closest to the floor and lightweight items above.
14. All cords running into walk areas must be taped down or inserted through rubber protectors to prevent tripping hazards.
15. Never stack material precariously on top of file cabinets or other high places.
16. Never leave lower desk or cabinet drawers open, a tripping hazard. Use care when opening and closing drawers to avoid pinching fingers.
17. Do not open more than one upper drawer at a time, particularly the top two drawers on tall file cabinets.
18. Always use the correct lifting technique. Never attempt to lift or push an object that is too heavy. Contact the supervisor when help is needed to move a heavy object.
19. When carrying objects, use caution in watching for and avoiding obstructions or loose material.
20. Plug all electrical equipment into appropriate wall receptacles, or into an extension of only one cord of similar size and capacity. Three-pronged plugs should be used to ensure continuity of ground.
21. Keep individual heaters at work areas clear of combustible materials such as drapes or waste from wastebaskets. Use newer heaters that are equipped with tip-over switches.
22. Keep appliances such as coffeepots or microwave ovens in working order and inspect them for signs of wear, heat or frayed cords.
23. Use equipment such as scissors or staplers for their intended purposes only, and do not misuse them as hammers, pry bars, screwdrivers. Misuse can cause damage to the equipment and possible injury to the user.
24. Store cleaning supplies away from edible items on kitchen shelves.
25. Store cleaning solvents and flammable liquids in appropriate containers.
26. Keep solutions that may be poisonous or are not intended for consumption in well-labeled containers.

EMERGENCY ACTION PLAN

The purpose of this plan is to protect all employees of Lucas General Contracting in the event of an emergency and to be prepared to handle these emergencies in an efficient manner. The responsibilities include providing for the safety of personnel, preserving facilities and equipment, protecting the public from on site incidents that affect the health and safety of the community, and contributing to overall community emergency preparedness.

Evacuation Procedures

The evacuation procedures are specific for each section of each building. Every employee shall be made aware of evacuation procedures specific to each location.

Evacuation maps shall be strategically placed for easy references. These maps shall contain fire extinguishers locations as well as exit locations.

When an evacuation of a work area or at the LGC office is called, the following procedures will be adhered to:

1. All employees will stop what they are doing.
2. Shut down all equipment(only if the employee is not in any immediate danger)
3. The employee will then follow the exit route established for the area in which he/she is working to evacuate the facility and go to the designated assembly area.
4. Employees must be accounted for and must check in with their supervisor to ensure all LGC personnel are accounted for.

Communications

A method of communications is needed to alert employees to the evacuation or to take other action as required in the plan. Alarms should be audible or seen by all people in the locations. The alarm should be distinctive and recognizable as signal to evacuate the work area or perform actions designated under emergency action plans.

Accounting for Personnel

The person in command will need to know all personnel have been accounted for. All supervisors are required to account for their personnel.

Rescue and Medical Duties for employees

In the event of a medical emergency, employees are directed to contact emergency medical services by dialing 9-1-1 immediately.

Employees are not required to perform any rescue or medical duties, however employees trained in first aid and CPR may render care appropriate to their level of training only! At no time should an employee be directed to perform emergency duties, which may endanger his/ her life.

FIRE SAFETY PROCEDURES (PROJECT SITE)

INTRODUCTION

Fire can present a significant threat to workers who may have limited access & egress to a work site. Although fire risks can be reduced, they cannot be eliminated on a construction site with multiple contractors. This section will provide best practices to reduce the risk of fire with the LGC work-zone.

ACCOUNTABILITY

Fire prevention is everyone's responsibility but the overall responsibility lies with the LGC Superintendents and Subcontractor's Foreman. Fire prevention is the best method of controlling a fire situation and should begin when the project is being planned. Workers who witness a fire hazard are authorized to address the issue immediately.

APPLICATION

When prevention fails, the following procedures are critical to saving lives and property.

1. Fire is observed, sound an alarm and notify everyone in the area.
2. Evacuate the area and call 911 for fire department assistance
3. Account for all LGC personnel
4. Notify your supervisor

FIRE PREVENTION PROCEDURES

Cutting/Grinding & Welding- operations can generate sparks and release slag on to combustible material, i.e. oiled forms, trash bundle, boxes and other shipping products. When performing these operations a fire extinguisher must be readily available (within 25' of point of operation). All combustible material should be moved away from the work-zone and the area should be watched closely to ensure no smoldering material is left behind.

Access & Egress- All access ways must be kept clear of obstructions at all times. Debris, poor housekeeping or scaffold repairs should not prevent workers from exiting the area immediately.

Superintendents & Subcontractor's Foremen should consider how to extricate workers from a complex structure prior to allowing workers to enter. Provisions for such extrication should be readily available.

Fire Extinguishers

Fire extinguishers are the first line of defense against fire. Major fires, resulting in financial, as well as, human losses usually begin as small, controllable fires ignited by welding, grinding or sweating pipe.

Equipment Selection and Distribution

1. Fire extinguishers provided with each Oxy Acetylene Setup are 10 lb ABC dry chemical and should accompany the torch, not the cart.
2. Fire extinguishers provided by the GC or controlling entity should be a supplement to PCS provisions and should be requested when not observed within 50 feet or less in a work-zone.

Inspection

1. Inspection is a quick check that an extinguisher is available and will operate. This is accomplished by physically checking that all fire extinguishers are in their designated places, have not been tampered with and no obvious physical damage is observed.
2. Fire extinguishers inspections shall be conducted when initially placed into service and monthly thereafter. Inspections shall be recorded on the back of the fire extinguisher inspection tag.

*NOTE: Employees are not designated to fight fires. Any use of fire extinguishers is considered voluntary and thus explained in the training session.

SUBSTANCE ABUSE POLICY

Policy Statement

Lucas General Contracting, recognize the problems created by drug and alcohol abuse and the need to develop prevention and treatment programs. Lucas General Contracting has a commitment to protect people and property, and to provide a safe working environment. The purpose of the following program is to establish and maintain a drug free, alcohol free, safe, healthy work environment for all of its employees.

Definitions

Company Premises – all property, facilities, land, buildings, structures, automobiles, trucks, and other vehicles owned, leased or used by the company. Construction job sites for which the company has responsibility are included.

Prohibited Items and substances – Prohibited substances include illegal drugs (including controlled substances, look alike drugs, and designer drugs), alcoholic beverages, and drug paraphernalia in the possession of or being used by an employee on the job.

Employee – Individuals who perform work for Lucas General Contracting, including: management, supervision, engineering, tradesmen, and clerical personnel.

Accident - Any event resulting in injury to person or property to which an employee, or contractor/contractor's employee, contributed as a direct or indirect cause.

Incident – An event, which has all the attributes of an accident, except that no harm was caused to person or property.

Reasonable Cause – Reasonable cause shall be defined as tardiness, excessive absenteeism, and erratic behavior such as noticeable imbalance, incoherence, and disorientation.

Rules, Disciplinary Actions and Grievance Procedures

A. Rules

All employees must report to work in a physical condition that will enable them to perform their jobs in a safe and efficient manner.

Employees shall not:

Use, possess, dispense, or receive prohibited substances on or at the job site; or

Report to work with any measurable amount of prohibited substances in their system.

B. Discipline

When the company has reasonable cause to believe an employee is under the influence of a prohibited substance, for reasons of safety, the workers may be suspended until the results are available.

1. Applicants testing positive for drug use will not be hired.
2. Employees who have not voluntarily come forward, and who test positive for a drug use, will be terminated.
3. Employees who refuse testing procedures will be terminated.
4. Employees found in possession of drugs or drug paraphernalia will be terminated.
5. Employees found selling or distributing drugs will be terminated.
6. Employees found under the influence of alcohol while on duty, or while operating a company vehicle, will be subject to termination.
7. Any subcontractor's employees violating items 1 – 6 above will be removed from the jobsite.

C. Prescription Drugs

Employees using a prescribed medication, which may impair the performance of job duties, either mental or motor functions, must immediately inform their supervisor of such prescription drug use. If

Lucas General Contracting is made aware of an employee taking prescription drugs through we will require medical certification/release from the prescribing physician in order for the employee to continue to work while taking the prescription. For the safety of all employees, the company will consult with you to determine if a re-assignment of duties is necessary.

The company will attempt to accommodate your needs by making an appropriate re-assignment. However, if a re-assignment is not possible, you will be placed on temporary medical leave until released as fit for duty by the prescribing physician.

Drug and Alcohol Testing

The parties to this policy and program agree that under certain circumstances, the company will find it necessary to conduct drug and alcohol testing. While “random” testing is not necessary for the proper operation of this policy and program, it may be necessary to require testing under the following conditions.

1. A test may be administered in the event a supervisor has a reasonable cause to believe that the employee has reported to work under the influence, or is or has been under the influence while on the job; or has violated this drug policy. During the process of establishing reasonable cause for testing, the employee has the right to request his on-site representative to be present.
2. Testing is required if an employee is involved in a workplace accident/incident or if there is a workplace injury.
3. Testing may be required as a part of a follow-up to counseling or rehabilitation for substance abuse, for up to a one-year period.
4. Employees may also be tested on a voluntary basis.

Each employee will be required to sign a consent and chain of custody form, assuring proper documentation and accuracy. If an employee refuses to sign a consent form authorizing the test, ongoing employment by the company will be terminated.

Drug testing will be conducted by an independent accredited laboratory. Lab tests may consist of either blood or urine tests, or both, as required.

The company will bear the costs of all testing procedures unless the employees test results in a positive drug screen.

Post Accident/Incident Drug and Alcohol Testing Procedures

Drug and Alcohol Testing is required immediately after an employee is involved in a workplace accident/incident. Such testing shall be conducted by the medical clinic designated by Lucas General Contracting to treat the employee. Where an employee is hospitalized for a workplace injury, it is the policy of Lucas General Contracting that such an employee be tested for drugs and alcohol as soon as practical. If for any reason, the hospital cannot accommodate this request, the employee shall submit to a drug and alcohol test at the medical clinic designated by Lucas General Contracting.

1. No employee shall be allowed to drive him/herself to the medical clinic if it is observed that such employee is intoxicated or under the influence of drugs.
2. No employee shall be eligible to return to work until drug and alcohol test results are confirmed as negative. If the drug or alcohol test result is positive, the employee will be terminated.
3. Any employee who submits to a post accident/incident drug and alcohol test shall be paid by Lucas General Contracting starting with the date of the incident/accident and until results are received by LGC.

4. No employee shall be paid for any time lost if the post accident/incident drug and alcohol test is positive.
5. Each employee will be required to provide a signed chain of custody form to assure proper documentation and accuracy.
6. Each employee will be required to provide a signed consent form to be submitted with the accident report to the Director of Safety.

It is the responsibility of the Superintendent to notify the Director of Safety immediately after a workplace injury by contacting them by phone or completing a post accident drug testing form. The Chief Financial Officer will serve as the point person for receipt of all post accident/incident drug and alcohol testing results, and ensure that employees are properly compensated for their time they miss work while waiting for drug test results. All Subcontractors must have similar Substance Abuse policies similar to LGC. Any Subcontractor employee found in violation of the above Substance Abuse policies will be removed from LGC's jobsite immediately.

REQUIRED POSTINGS

The Occupational Safety and Health Administration requires that certain notices, signs, or posters be posted in a conspicuous place where employees can readily see them or where notices to employees are customarily displayed. Minimum posting requirements include the following:

- **Labor Law Poster**
- **OSHA Job Safety and Health Poster**
- **Emergency Contact List (Site Specific)**
- **MSDS Notice to Employees** : this notice advises employees that Material Safety Data Sheets for products in use by LGC Subcontractors and vendors are available for their review.
- **OSHA Annual Summary** the summary, OSHA 300A form is contained within a networked computer system with access from each office. The summary is required to be posed only from 1 February to 30 April.
- **Emergency Evacuation Map (Site Specific)**
- **Medical Facility - Address, Phone & Directions (Site Specific)**
- **Code of Safe Practices**

Construction sites in California without a jobsite trailer may keep the Labor Law Postings and the OSHA Job Health and Safety Poster in a binder. The Emergency contact information, Code of Safe Practices and the map to the nearest medical facility must be posted and readily accessible to the employees.

All other States must post the required posters in an office trailer, job shack or inside the lid of a tool box.

All required documents must be posted in both English and Spanish and are available by contacting the Superintendent or the Human Resources Department.

VIOLENCE IN THE WORKPLACE

INTRODUCTION

Lucas General Contracting recognizes the value of being the employer of choice and strives to create a work environment that coincides with that value. Field and office workers should never experience violence, threats or intimidation in the normal course of their work experience at LGC.

Workplace violence usually involves a threat of violence, or a physical act of violence resulting in a fatal or nonfatal injury, by a current or former worker, supervisor or manager; a current or former spouse or lover; a relative or friend; or some other person who has a dispute involving a worker of the workplace.

ACCOUNTABILITY

All employees are responsible to report any acts of violence, threats, intimidation or inappropriate behavior. Supervisors at all levels must maintain a zero tolerance policy for violence in the workplace.

Displays of violence, intimidation or threats that are not recorded and managed appropriately may develop into a much larger problem.

APPLICATION

Lucas General Contracting maintains a zero tolerance policy on Violence in the workplace. Violence can be described as the following:

VIOLENCE IN THE WORKPLACE BEST PRACTICES

1. Effectively communicating the LGC anti-violence policy to all workers, supervisors or managers. (especially new hires)
2. Continually improve management and workers communicate with each other.
3. Increasing awareness by workers, supervisors and managers of the warning signs of potential workplace violence.
4. Controlling access to, and freedom of movement within, the workplace by non-workers, including recently discharged workers or persons with whom one of our worker's is having a dispute.
5. Recommend counseling to workers, supervisors or managers who exhibit behavior which may lead to physical or verbal abuse of co-workers.
6. Ensure that all reports of violent acts, threats of physical violence, verbal abuse, property damage or other signs of strain or pressure in the workplace are handled effectively by management and that the person making the report is not subject to retaliation by the person making the threat.
7. Ensure that worker disciplinary and discharge procedures address the potential for workplace violence.
8. Insubordination or other disrespectful conduct
9. Possession of dangerous or unauthorized materials, such as explosives, firearms or weapons, in the workplace

SUBCONTRACTOR SAFETY PROGRAM

LGC fully expects Subcontractors to *actively* participate in the Health, Safety and Environmental programs while working on LGC projects, or at any location when contracted to and in the course of work for Lucas General Contracting.

Subcontractors are required to:

- Administer their own safety program.
- And/or adopt the content of the LGC Safety Manual.

When mandated subcontractors will be required to:

- Submit a copy of their safety plan and/or I.I.P.P.
- Submit a copy of their Hazardous Communication Binder (MSDS)
- Submit a copy of specific preventative plans as requested.
- Submit proof of certifications as requested.
- Submit training documentation as requested

Subcontractors must also comply with the following:

- Applicable government standards and regulations.
- Client requirements/programs that may be specified.
- The **site-specific** IIPP, and/or any other Federal, State and Local health & safety regulations applicable to a specific site or job.

Personal Protective Equipment (PPE)

- Subcontractor supervision is responsible for verifying that their employees are provided with and use the appropriate PPE as required and as needed.
- Mandatory basic PPE requirements are as follows:
 - Hardhats
 - Eye Protection 100% (eyewear must meet ANSI standards)
 - Side shields shall be utilized with prescription safety glasses.
 - Face shields must be worn in addition to eye protection whenever there is exposure to flying debris or sparks.
 - Hand Protection shall be used whenever a hand injury exists.
 - Footwear shall be appropriate for the type of construction being done.
 - Sleeveless shirts and shorts are not acceptable.

Specific PPE that may be required (not to be considered a complete list):

- Full body harness when fall exposures exist
- Lanyards and rope grabs
- Respiratory protection (includes dust masks)
- Hearing protection
- Welding/cutting protection
- Personnel in violation of PPE requirements will be asked to leave

Incident Reporting for Subcontractors

- Notify LGC of all significant Near Misses.
- Notify LGC of all Incidents/Accidents immediately.
- Conduct a formal investigation of all Incidents/Accidents.
- Submit copy of report to LGC's supervision within 24 hours.
- Serious Incidents will have a preliminary review ASAP after occurrence and a formal review within 48 hours.

Audits and Inspections

- Inspect work areas daily to ensure compliance
- Shall be conducted by a competent person designated by the subcontractor.
- Non-compliance issues are to be corrected as soon as reasonably possible.
- Subcontractor supervision is strongly encouraged to participate in project inspections with LGC supervision.
- Subcontractors are required to conduct one (1) formal inspection of their area(s) of responsibility at least weekly.
- Documentation of formal inspection shall be submitted to LGC Superintendent.

LGC Safety Orientation

- All subcontractor personnel shall be:
- Orientated prior to starting work on site specific emergency action/evacuation, location of first aid supplies and scope of work by LGC Superintendent.
- Trained on the hazards of the project.

Safety Meetings

- Weekly Safety Tailgate Meetings are to be held every Monday.
- Copies of the meeting minutes are to be submitted to LGC.

Worksite Monitoring

- LGC will monitor the subcontractor's work areas for compliance.
- This may include a review of all
 - Records
 - Maintenance logs and attendance at new worker safety orientations
 - Weekly Safety Meetings

Statistical Reporting

- If requested, shall submit a report detailing the following:
- Employees on-site per day
- Total man-hours per week and to date
- Number of first aids per week and to date
- Number of recordable incidents per week and to date
- Number of work days lost per week and to date
- Number of incidents (Near Misses) per week and to date
- Historical OSHA Statistics

Emergency Response

- Subcontractor supervision will review and become familiar with the overall project Emergency Response Plan.
- Subcontractor supervision will communicate this plan to all of their employees.
- If an emergency situation arises, subcontractor supervision will be responsible:
 - For the safe evacuation of their personnel to assembly areas.
 - Head counts shall be taken and reported to LGC's Project Superintendent.
- In the event one or more of your personnel is injured the same response plan shall still take place.
- Subcontractor Supervision is to assist with gathering witnesses.

Housekeeping

- There will be a daily clean up of all work areas and the trash generated from that day's activities
- Daily clean up shall include the Area being broom swept.

Compliance with the Health, Safety and Environmental Plan

Compliance with these health and safety guidelines and the Lucas General Contracting policies is mandatory to maintain a health and safe work place and to provide ongoing safety and respect to all parties. Non-compliance with this document or LGC site policies may result in suspension or termination of the subcontract.

To this end, LGC has developed a system of discipline to deal with infractions to the policies outlined within this manual. The disciplinary action may follow the list of guidelines below:

- On the first offense, the worker will be given a verbal warning.
- On the second offense, the worker will be given a written warning.
- On the third offense, the worker's employment will be suspended or terminated.

NOTE THAT CERTAIN SAFETY VIOLATIONS MAY RESULT IN IMMEDIATE DISMISSAL.

SECTION III

HAZARD CONTROL

ACCESS & EGRESS

INTRODUCTION

Lucas General Contracting generally relies on the Subcontractor or controlling entity to provide access & egress for work zones. The Subcontractor's Foreman has a direct responsibility to inspect the scaffolds, ladders or access ways prior to commencing work.

ACCOUNTABILITY

The LGC Superintendent is responsible for ensuring that appropriate access and egress has been provided for their Subcontractor's. Subcontractors are expected to protect their employees and have the right to refuse work where safe access and egress is not provided.

Stairwells

- Are required in all buildings or structures 2 or more stories or 24 feet or more in height or depth, suitable permanent or temporary stairways shall be installed as required in Section 1629(b)
- Stairways shall be at least 24 inches in width and shall be equipped with handrails, treads and landings. Temporary stairs shall have a landing not less than 30 inches wide in the direction of travel at each floor, or level, but never less than 1 landing for every 12 feet of vertical rise.
- 1 stairway shall be provided for access and exit for buildings and structures to 3 stories or 36 feet; if more than 3 stories or 36 feet, 2 or more stairways shall be provided. Where 2 stairways are provided and work is being performed in the stairways, 1 shall be maintained clear for access between levels at all times.
- A construction passenger elevator for hoisting workers shall be installed on all structures, 60 feet or more in height above or 48 feet in depth below ground level.
- Stairwells must be kept clear of debris and materials and should be lit when necessary.

Unfinished Floors

Prior to commencing work on unfinished floors, the LGC Superintendent must inspect the floor and adjacent operations to ensure a safe deck has been turned over. Prior to allowing workers on the floor, ensure the following:

- Ladder-way floor openings or platforms shall be guarded by standard railings with standard toe-boards on all exposed sides.
- Floor holes, into which persons can accidentally walk, shall be guarded by either a standard railing with standard toe-board on all exposed sides, or a floor hole cover of standard strength and construction that is secured against accidental displacement. While the cover is not in place, the floor hole shall be protected by standard railing.
- Screens shall be of such construction and mounting that they are capable of withstanding a load of at least 200 pounds applied horizontally at any point on the near side of the screen. They may be of solid construction, of grill work with openings not more than 8 inches long, or of slat work with openings not more than 4 inches wide with length unrestricted.
- Ensure the shoring is adequate for the deck itself and the intended load of rebar, workers and equipment. Visually inspect the shoring on a daily basis to ensure no modification or damage has occurred.

SCAFFOLDING

It is the policy of Lucas General Contracting that only properly trained employees of Subcontractors are allowed to use scaffolds.

Scaffolding on the job site can expose our Subcontractor's to serious risks of injury. Lucas General Contracting may hire a vendor to install a scaffold or use the controlling entities scaffold but in no case shall LGC personnel build modify or install a scaffold.

Prior to using a scaffold LGC Superintendent Foreman and Subcontractor's are required to inspect the scaffold using the following criteria:

GENERAL RULES-SCAFOLD SAFETY

1. The footings or sills for scaffolds shall be sound, rigid, and capable of carrying the maximum intended load without settling or displacement. Unstable objects such as barrels, loose bricks, or concrete blocks shall not be used to support scaffolding or planks.
2. Guardrails shall be installed on all open sides of scaffolds more than 10 feet above the ground or floor.
3. Scaffold 4-10 feet in height, with a minimum horizontal dimension in either direction of less than 45 inches, shall have guardrails installed.
4. Metal scaffolds shall be securely tied to the building or structure by means of a double looped No. 12 iron wire, or single looped No. 10 iron wire or equivalent at intervals not to exceed 30 feet horizontally and subject to the following:
 5. All working platforms must be fully planked and overlapped at least 12 inches
 6. All planking must be secured from movement (cleats).
 7. Screw jacks shall be used to level the scaffold.
 8. All brace connections shall be made secure with appropriate fittings.
 9. The height of a scaffold cannot exceed 4 times the minimum base dimension without outriggers or being tied off to a stable part of the building.
 10. Scaffolds shall be capable of supporting without failure at least 4 times the maximum intended load.
 11. Daily inspection of scaffolding on the job site must be made by a competent person. Inspections must be documented.

BAKER SCAFFOLD (rolling scaffolds, perry scaffolds)

1. Guardrails shall be installed on Baker Scaffolds more than 4 feet in heights.
2. Baker Scaffolds greater than 10 feet in height must be equipped with outriggers or secured to the building.
3. All casters shall be provided with a positive locking device to hold the scaffold in position.
4. When the scaffold is in use by any person, the wheels or casters shall be locked to prevent any movement.
5. When the Baker Scaffold platform is 6 feet or higher, bracing must be installed near the floor level for increased stability.

LADDERS

On some projects it is necessary to access the work zone via the use of a ladder. Ladders may be used for access and egress; however they may not be used for transporting equipment or materials to the work-zone. When a ladder is required for access, the Subcontractor's foreman must inspect the ladder prior to use by LGC personnel. The visual inspection must ensure the following best practices are adhered to.

Ladder Best Practices

- The use of ladders with broken or missing rungs or steps, broken or split side rails, or other faulty or defective construction is prohibited.
- Portable ladder feet shall be placed on a substantial base, and the area around the top and bottom of the ladder shall be kept clear.
- Portable ladders shall be used at such a pitch that the horizontal distance from the top support to the foot of the ladder is about one-quarter of the working length of the ladder (the length along the ladder between the foot and the top support). Ladders shall not be used in a horizontal position as platforms, runways, or scaffolds.
- Ladders shall not be placed in passageways, doorways, driveways, or any location where they may be displaced by activities being conducted on any other work, unless protected by barricades or guards.
- The side rails shall extend not less than 36 inches above the landing. When this is not practical, grab rails, which provide a secure grip for an employee moving to or from the point of access, shall be installed.
- Portable ladders in use shall be tied, blocked, or otherwise secured to prevent their being displaced.
- Never place a ladder in front of a door that opens toward the ladder unless the door is locked, blocked, or guarded.
- Do not place a ladder close to electric wiring or any operational piping (acid, chemical, sprinkler systems, etc.) where damage may occur.
- Always maintain a three point contact when climbing up or down ladders (i.e., 2 feet with one hand/2 hands with 1 foot).

COMPRESSED GAS CYLINDERS

INTRODUCTION

Oxygen and Acetylene as a fuel for torches required for cutting rebar and other steel. LGC recognizes the significant hazard presented with use of compressed gas cylinders, flammable ones in particular. The following procedures were developed to reduce the hazards associated with the use of Oxygen and Acetylene.

Transporting-Cylinders should be transported as close to a vertical position as possible with the regulators removed and the valve caps in place. Cylinders lifted by crane or hoist must use an approved cart with a lifting eye.

Storage-Cylinders may only be stored with the caps in place, in a vertical position with the gauges removed. Cylinders may not be stored in carts unless the cart is equipped with a 5' 1/2 hour rated fire wall.

Usage- Cylinders may only be used in a vertical position with undamaged, functional regulators attached. Hoses must be free of breaks, kinks, wear or burn spots. Torches must come with flashback arrestors.

Fire Control- Oxygen and Acetylene shall not be used without a 10lb fire extinguisher placed no further than 25 feet from the torch end. Cylinders shall be protected from sparks, flame or electricity by positioning or shielding.

COMPRESSED GAS CYLINDERS

BEST PRACTICES

1. All cylinders shall be stored in an upright position and securely strapped or tied around the body of the cylinders by rope or chain.
2. Oxygen and Fuel shall be separated by at least 20' or a ½ hour rated fire wall.
3. Valve protection caps shall be kept on cylinders except when in use.
4. Oxygen cylinders shall be separated from flammable and combustible materials (especially grease).
5. Always store compressed gas cylinders in a well-ventilated area protected from direct sunlight.
6. Regulators and pressure gauges shall be used only with gasses for which they were designed.
7. When in use, cylinders should be secured to a cart that will not tip over.
8. Lifting Cylinders will only be accomplished in a cart approved for that purpose.
9. Torch carts must have a 10 lb chemical fire extinguisher provided.

CONFINED SPACE ENTRY

INTRODUCTION

Accidents involving confined space entry are rare but often fatal when they occur. When one worker goes down it is human nature to help and in a contaminated environment they become victims as well. Air contamination cannot be seen and cannot always be smelled and accidents as a result happen immediately! Some workers have experienced heart attacks and or other non-injury related illnesses while working in a confined space. If you didn't plan on how to get your buddies out in an emergency then you will quickly run out of time to assist them.

Definition

1. A space large enough for a person to enter and perform work.
2. Has limited entry or exit.
3. Is not a space designed for continuous occupancy.

Non-Permit: Confined space means the work area does not contain atmospheric hazards capable of causing death or serious physical harm.

Permit Required: Workers could be trapped, crushed, asphyxiated or exit/rescue is difficult or improbable. Contains any other recognized serious safety or health hazard including hazardous environment.

Any employee entering a confined space must be trained in the hazards associated with confined space entry, and must be authorized by a LGC Supervisor to enter.

The LGC Director of Safety must authorize any entry of LGC employees into Permit Required Confined Spaces prior to commencing operations.

CRANES

INTRODUCTION

Lucas General Contracting recognizes the inherent risk associated with crane operations. The following policies are provided to help insure that operations involving hoisting and the application of ropes, slings, chains and accessories are done safely.

ACCOUNTABILITY

The safe operation and proper maintenance of cranes on the site shall be the overall responsibility of the Subcontractor or Vendor. The Subcontractor or Vendor shall also be held accountable for compliance with OSHA crane regulations for all cranes or derricks on the site whether owned, leased or rented. Only Crane companies on the LGC approved Subcontractor list shall be used.

Superintendents

LGC personnel are not authorized to operate tower cranes at any time.

The Subcontractor or vendor is responsible for ensuring that all crane operations are conducted in accordance with the best practices identified below:

Crane Best Practices

1. All cranes in use require an annual certification inspection and must be kept in the crane cab.
2. All operators must have a current NCCCO Certification. Exception: (1) Mobile cranes having boom length of less than 25 feet or a maximum rated load capacity of less than 15,000 pounds.
3. Cranes must be inspected prior to each use to ensure they are fit for operation.
4. Only qualified persons shall give signals to crane operators.
5. The swing radius of crane cab shall be protected.
6. Cranes shall not be left unattended with a load suspended.
7. No load shall be swung over personnel and no person shall work under suspended loads unless the load is effectively blocked to prevent it from falling.
8. It is unlawful and extremely dangerous to operate a crane within 20 feet of a live voltage line.
9. Truck cranes shall have a boom angle indicator located so the operator can see it when he is lifting a load.
10. Truck cranes shall have the outriggers firmly and securely set before attempting to lift a load.
11. On soft ground, "blocking" shall always be used under outrigger floats to prevent deflection or sinking. Outrigger shall always be fully extended as per manufacturer's recommendation.
12. Crane Cabs must have a serviceable fire extinguisher in the cab.
13. Cranes must be level prior to lifting a load. An unlevelled crane could side load the boom.
14. Gantry cranes shall have their controls clearly marked to indicate function.
15. Operators of Gantry cranes shall maintain visual contact with their load at all times.
16. Pendant controlled cranes shall have a warning light on the overhead travel bridge.
17. Radio controlled cranes shall have an audible warning horn or device.

Overhead Cranes

1. Cranes require a daily & bi-annual inspection and 4 year & annual certification.
2. Cranes must be inspected prior to each use to ensure they are fit for operation.
3. Only qualified & authorized workers are authorized to perform any work on LGC cranes.
4. Only qualified persons shall operators the crane controls.
5. Cranes shall never be left unattended with a load suspended.
6. No load shall be swung over personnel and no person shall work under suspended loads unless the load is effectively blocked to prevent it from falling.
7. One bay must be maintained between each operating crane and at no time shall two cranes occupy the same bay.
8. The hook must be directly centered over any load that it is attached to it.

Loading & Unloading Trailers

1. Trailers with damaged, broken or missing flooring planks must be removed from service.
2. Offloading a damaged trailer must be done under the supervision of the Shop Foreman.
3. Trailer must be loaded in such a way that no danger is posed to the workers expected to offload the trailer.
4. Overloading of trailer (even temporarily) is not allowed.
5. Overhanging loads may not hang lower than $\frac{1}{4}$ the distance from the top of the trailer to the ground.
6. In no case shall a load or parts of the load extend from the side of the trailer for more than 12". All overhanging loads must be flagged with a durable and highly visible flag.

ELECTRICAL SAFETY

INTRODUCTION

The risk of electrocution is generally limited to equipment maintenance or the use of faulty devices. LGC has made every effort to ensure that all power terminals meet the highest standards of safety and reliability. At all construction sites, GFCIs, Ground Fault Circuit Interrupters, are required to be used with all temporary power sources.

ACCOUNTABILITY

Subcontractors and vendors must ensure that all electrical power supplies meet the minimum safe standards detailed in this manual.

Electrical Panels

All electrical panels in the field must meet the following criteria:

1. Panels must be clearly marked, indicating power and service.
2. Panels may not have any signs of burns or damage to the interior or exterior.
3. Panels must have no missing breakers or covers on any breaker ports
4. Panels must be marked indicating "Do Not Block or Cover" in English and Spanish.
5. Panels must have a 3' clearance maintained at all times.

Wall Outlets

All electrical outlets in the field must meet the following criteria:

1. Outlets may not have any signs of burns or damage to the interior or exterior.
2. The face plate may not be broken or damaged in any way.
3. Outlets in the shop must be GFI type for all locations.
4. Outlets in kitchen areas or next to water supplies shall have GFI circuits.
5. Power Strips must be approved for use in industrial locations.

Extension Cords

1. Shall be inspected regularly for wear and damage.
2. Shall not be used as a substitute for permanent wiring.
3. Should not be plugged together to make a longer cord. Use in one continuous length.
4. Never pull a cord to disconnect; remove it by the plug.
5. Do not place cords under rugs, strung through doorways, windows, walls, or ceilings.
6. Damaged cords must be removed from service and repaired or destroyed immediately.
7. Use only approved cords outdoors. The word “outdoor” or the letters “WA” on the sheath.

Repairs

All repairs to electrical systems or components will be conducted by a licensed electrician and or their designee. No LGC or Subcontractor’s employee is authorized to work on LGC or Subcontractor’s equipment or wiring or electrical components unless they are qualified to perform the work and have received direction from their Supervisor.

EQUIPMENT SAFETY

INTRODUCTION

Lucas General Contracting understands the value of training our Superintendent’s and empowering them to make the appropriate safety decisions in the field. Superintendents are the front line defense against accidents and incidents on the job-site.

ACCOUNTABILITY

Equipment (Subcontractor’s)

Subcontractor’s Foreman will ensure the following best practices are being followed:

1. Equipment will only be repaired by qualified technicians
2. Equipment must have emergency kill switches installed regardless of the original configuration.
3. No LGC or Subcontractor’s personnel shall operate equipment without prior authorization and training.
4. No LGC or Subcontractor’s equipment shall be operated without the safety guards in place.
5. No equipment shall be serviced, adjusted, cleaned or re-tooled unless proper LOTO procedures are first applied.
6. A schedule of preventative maintenance shall be used to ensure equipment remains at peak operating performance.
7. All equipment shall be inspected prior to use and immediately removed from service when not operating performance.

Any equipment not operating at 100% or operating in an unsafe manner must be reported to the Subcontractor’s Foreman and LGC Superintendent and removed from service.

EXCAVATING AND TRENCHING OPERATIONS

INTRODUCTION

Lucas General Contracting may at times be required to enter excavations, footings or other types of pits. Creating, maintaining or providing protective system for excavations is outside of the normal scope of our work. LGC Superintendent’s are trained to inspect excavations to ensure they are safe for their workers to enter. The following section provides inspection procedures and best practices designed to reduce the risks associated with excavations.

ACCOUNTABILITY

Foreman (Subcontractor)

The Subcontractor's foreman is responsible for ensuring an excavation is safe to enter prior to allowing their workers to enter. No LGC personnel are authorized to install protective systems, create or modify an excavation.

The Subcontractor's foreman must ensure the following Best Practices are adhered to:

Trenching & Excavation Best Practices

1. Trenches & Excavations in excess of 5' in vertical depth must have protective systems installed.
2. Trenches & Excavations in excess of 4' must have a ladder or similar exit 25' from each worker.
3. Excavations with free standing water or water intrusion must have a method for extracting the water. Employees may not enter an excavation with standing water unless adequate precautions have been taken.
4. The Foreman should review the excavation permit, the name of the competent person and the plan for protective systems.
5. If the work environment is suspected of being contaminated, the foreman has the responsibility to ask the appropriate responsible party to verify the safety of the excavation.
6. Protective systems for excavations deeper than 20 ft. shall be designed by a registered engineer with design plans made available for inspection.
7. Employees must be protected from excavated or other material by keeping such material 2 ft. from the excavation edge or by using barrier devices.
8. Employees must be protected from falling materials by scaling, installation of protective barriers, or other methods.
9. **LGC personnel and Subcontractor's employees are not authorized to enter an excavation greater than 5' deep without protective systems installed.**

FALL PROTECTION POLICY

INTRODUCTION

The fall protection standard covered under 29 CFR part 1926 (OSHA Code of Federal Regulations for the construction industry) is superseded by the California Code of Regulations Article 24 for California job site locations, shops & offices. In some cases LGC policy is more stringent than the Federal or State Standard in controlling fall exposures. Whenever Contractor policy is more stringent, employees shall follow contractor policy.

ACCOUNTABILITY

LGC Subcontractor's and vendors are required to wear and use fall protection equipment when working at heights of 6' or greater, and anytime additional hazards exist within the fall zone. For example: Electrical Hazard, Impalement Hazard etc..

Superintendents-must ensure all required Fall Protection Equipment is utilized by the Subcontractor's and vendors in the field. Through pre-task and pre-project planning the fall protection needs on each project should be identified well in advance.

Subcontractor's and Vendors must ensure that all workers exposed to a fall must have the appropriate training and fall protection equipment prior to commencing work. The Subcontractor's foreman is responsible for ensuring each worker inspects their equipment prior to use each day.

In addition the Superintendent and Subcontractor's Foreman must inspect the work area to ensure the **work zone** is in compliance with the following regulations: (Review Access and Egress Section of this manual)

1. Work zones with an unprotected side or leading edge, 6 feet high or more must be protected by the use of guardrail, safety net system.
2. Holes in decking must be covered and shall be capable of safely supporting the greater of 400 pounds or twice the weight of the employees, equipment and materials that may be imposed on any one square foot area of the cover at any time. Covers shall be secured in place to prevent accidental removal or displacement, and shall bear "Opening--Do Not Remove." Temporary markings shall not be used.
3. When workers are exposed to falling objects, the Subcontractor's foreman must ensure the Subcontractor or responsible party has erected toe boards, screens or guardrail systems to prevent objects from falling from higher levels. The Subcontractor's foreman must not allow his workers to be exposed to this hazard without protection.
4. All LGC and Subcontractor's workers shall be "tied off" above 6 feet, which requires employees working on Rebar Columns and Walls be equipped with fall protection. Employees below 24 feet and not exposed to any impalement hazard in the fall zone may travel from point-to-point without the 100% tie off requirement until they stop traveling.
5. The use of a body belt or safety belt as part of a personal fall arrest system is prohibited.
6. For heights above 24 feet, or where impalement or other hazards exist in the fall zone, all employees are required to be 100% "tied off". This means that employees are equipped with a fall arrest system, and tied off at all times, including horizontal and vertical point-to-point travel.
7. Holes in decking must be covered and shall be capable of safely supporting the greater of 400 pounds or twice the weight of the employees, equipment and materials that may be imposed on any one square foot area of the cover at any time. Covers shall be secured in place to prevent accidental removal or displacement, and shall bear "Opening--Do Not Remove." Temporary markings shall not be used.
8. When workers are exposed to falling objects, the Subcontractor's foreman must ensure the Subcontractor responsible party has erected toe boards, screens or guardrail systems to prevent objects from falling from higher levels. The foreman must not allow his workers to be exposed to this hazard without protection.
9. Workers "CONNECTING" steel are required to wear fall protection when working above 15' feet and to be tied off at all times when working above 30'.
10. For all structural steel erection work (bolting, welding) other than "connecting" at heights above 15 feet, or where impalement or other hazards exist in the fall zone, all employees are required to be 100% "tied off". This means that employees are equipped with a fall arrest system, and tied off at all times, including horizontal and vertical point-to-point travel.

FALL PROTECTION SYSTEMS

Guardrail Systems

Top Rail

1. Must be 42 to 45 inches high.
2. When Stilts are used, the top edge may exceed the 45-inch height, provided the guardrail system meets all other criteria of this section.
3. Must withstand a force of at least 200 lbs in any outward or downward direction at any point along the top rail.
4. When 200 lbs of force is exerted on the top rail during inspection the top rail must not deflect to a height less than 39 inches above the working level.
5. The ends of all top rails shall not overhang the terminal posts, except where the overhang does not present a projection hazard.
6. Steel or plastic banding shall not be used as top rails.
7. If wire rope is used as a top rail, it must be flagged every 6 feet with highly visible material.

Mid Rail

1. Shall be used when there is no wall or parapet wall at least 21 inches high.
2. Shall be installed at a height midway between the top rail and the walking/working level.
3. Must withstand, without failure, a force of 150 lbs in any outward or downward direction at any point along the mid rail.
4. Steel or plastic banding shall not be used as mid rails.
5. Guardrail systems shall be surfaced as to prevent injury to an employee from punctures, lacerations, and to prevent snagging of clothing.

Personal Fall Arrest Systems

1. Full body harnesses, positioning hooks and Y-lanyards are provided by Subcontractor's for each employee.
2. The Subcontractor's are responsible for ensuring that the bi-annual inspection of each harness, lanyard & positioning hooks is conducted and will provide new equipment as required. Inspection procedures are per the manufacturers recommendations.
3. The Subcontractor's foreman on the jobsite requiring the use of fall protection is required to ensure the inspection and proper use and care of each piece of fall protection equipment on a daily basis. All equipment not passing inspection is required to be replaced immediately.
4. The attachment point of the body harness shall be located in the center of the wearer's back near shoulder level, or above.
5. The attachment point for positioning hooks and lanyards should be to anchor point capable of supporting at least 5,000 lbs.
6. When anchoring to rebar, the attachment point must be to the inside bar.



Warning Line Systems

The Subcontractor's foreman should consider the following criteria when evaluating warning line systems:

1. Consist of ropes, wires, or chains, and supporting stanchions erected
2. The rope, wire, or chain shall be flagged at not more than 6-foot intervals with a highly visible material.
3. The rope, wire, or chain shall be rigged and supported in such a way that its lowest point is not less than 34 inches from the waling/working surface and its highest point is no more than 39 inches from the walking/working surface.
4. After being erected, with the rope, wire, or chain attached, stanchions shall be capable of resisting, without tipping over, a force of at least 16 lbs applied horizontally against the stanchion, 30 inches above the walking/working surface, perpendicular to the warning line, and in the direction of the floor, roof, or platform edge.
5. The rope, wire, or chain shall have a minimum tensile strength of 500 lbs, and after being attached to the stanchions, shall be capable of supporting, without breaking the loads applied to the stanchions.

TRAINING

All Subcontractors' employees shall be trained by their foreman or other competent person on the following Fall Protection Topics:

1. Identifying fall hazards in the work zone and when to tie-off.
2. Use and inspection of fall protection equipment.
3. Appropriate attachment points.

HAZARDS ASSOCIATED WITH REINFORCING STEEL

INTRODUCTION

Lucas General Contracting recognizes the risks associated with reinforcing steel or other similar projections. The following section has been developed in order to eliminate the risk of impalement, cuts, punctures or other injuries involving the use of reinforcing steel.

ACCOUNTABILITY

The Subcontractor is responsible for ensuring all exposed vertical steel and other similar projections are protected by means described in this section.

In the event of an accident or inspection, the Subcontractor would be considered the “exposing Subcontractor” and would be cited for allowing workers to be exposed to unprotected protrusions.

In those rare cases where LGC is responsible for providing the required protection, this section will be followed in the application of protective devices.

APPLICATION

Types of Protective Devices:

Job-Built: As used in this section, protective covers and troughs usually constructed at the job-site of wood or other materials of equal or greater strength and designed specifically for covering exposed ends of reinforcing steel or other similar projections at a specific job-site.

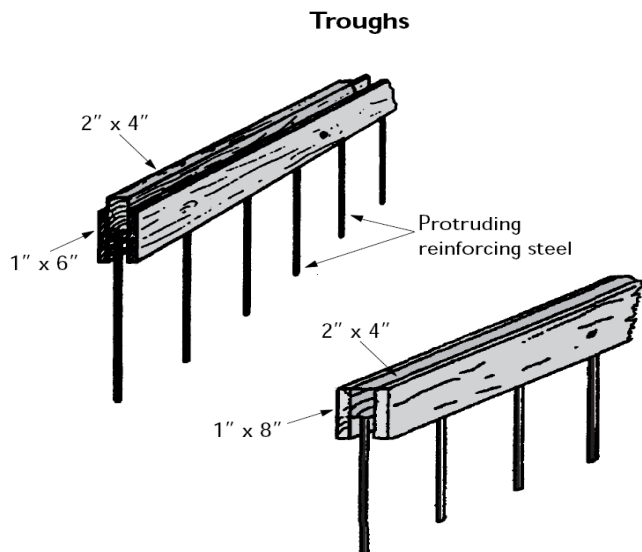

Protective Covers: Manufactured or job-built apparatus designed to cover exposed ends of reinforcing steel or other similar projections so as to prevent impalement.

Protective Covers

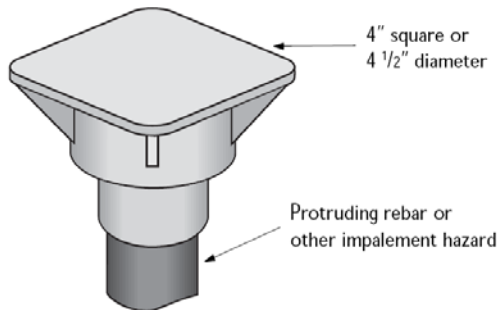

Troughs: Manufactured or job-built protective covers designed to cover two or more exposed ends of reinforcing steel or other similar projections so as to prevent impalement, and which meet the applicable requirements in subsection (d).

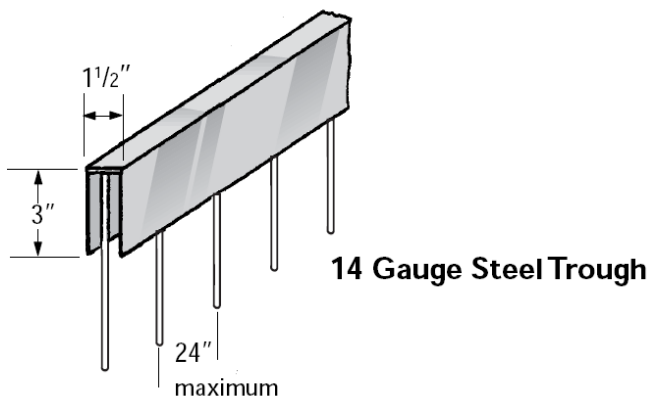

When is Protection Required?

Workers working at the same surface level or above as exposed protruding reinforcing steel or other similar projections shall be protected against the hazard of impalement by guarding exposed ends with protective covers, or troughs.

Protection may be provided in the following forms:

1. Guardrails or barriers
2. Approved fall protection systems
3. Protective covers as specified in the previous section.

Reinforcing Steel Best Practices & Inspection Criteria

1. Protective covers shall have a minimum 4-inch by 4-inch square surface area, or if round, a minimum diameter of 4 1/2 inches.
2. Manufactured protective covers shall be marked with the manufacturer's name/ logo.
3. Job-built protective covers must match the diagrams provided in this manual. Job-built protective covers that do not match the diagrams must be designed by an engineer with a copy of the engineering drawings made available to LGC.
4. All reinforcing steel extending up to 6' must be protected in an appropriate manner.
5. Form stakes and stakes used to support column braces must be protected.
6. Workers must be protected from horizontal bar when it protrudes into an access way.
7. Workers are not be allowed to work over 6' without approved fall protection devices.
8. Workers must use 100% tie off procedures when working above exposed rebar. 100% tie-off mean a Y-Lanyard with two hooks or a retractable device. The point to point allowance does not apply when unprotected rebar is beneath the worker.
9. Long sleeve shirts and gloves are highly recommended for iron workers.
10. Workers must be advised of the hazards of reinforcing steel via a tailgate safety meeting.
11. Work areas must be inspected daily to ensure that all rebar caps/troughs are in place prior to commencing work or returning from a break.

HAZARDS ASSOCIATED WITH STRUCTURAL STEEL ERECTION

INTRODUCTION

Lucas General Contracting recognizes the risks associated with structural steel erection. The following section has been developed in order to eliminate the risk of falls, struck-by, crushed-by or other injuries involving the process of structural steel erection.

ACCOUNTABILITY

The Subcontractor is responsible for ensuring all structural steel procedures are followed by means described in this section.

Structural Steel Best Practices & Inspection Criteria

1. Steel erection shall not commence until written notification is received from the General Contractor indicating:
 - A. Concrete has attained sufficient strength to support the loads imposed during the steel erection process.
 - B. Repairs, replacements or modifications to anchor bolts where approved by the project structural engineer.
2. Adequate access into and through the site for safe delivery and movement of equipment and materials to be erected shall be provided.
3. All hoisting operations shall be pre-planned. LGC requires a VEP, Vertical Erection Plan.
4. Cranes used in steel erection shall be visually inspected prior to use by a competent person on each shift.
5. A qualified rigger shall inspect the rigging prior to each shift.
6. Structural stability shall be maintained at all times during the erection process.

7. At no time shall there be more than four floors or 48 ft., whichever is less, of unfinished bolting or welding above the foundation or uppermost permanently secured floor, except where structural integrity is maintained as a result of the design.
8. A fully planked or decked floor or nets shall be maintained within two stories or 30 feet, whichever is less, directly under any erection work being performed.
9. Metal decking bundles shall be landed on framing members so that enough support is provided to allow the bundles to be un-banded without dislodging the bundles from the support.
10. Roof & Floor holes and openings shall be covered.
11. Covers shall be secured to prevent accidental displacement.
12. All covers shall be painted with high-visibility paint or marked with the word "Hole" or "Cover".
13. All columns shall be anchored by a minimum of 4 anchor bolts.
14. All columns shall be evaluated by a competent person to determine whether guying or bracing is needed.
15. A steel joist or girder shall not be placed on any support structure unless such structure is stabilized.
16. Steel joists and girders shall not be used as anchorage points for a fall arrest system without written approval from a qualified person.
17. Construction loads shall not be placed on any structural steel framework unless such framework is safely bolted, welded or otherwise adequately secured.
18. Taglines shall be used on all hoisted loads that expose employees to the swing of the load.
19. Whenever possible, "connectors" must straddle the beam instead of walk along the top flange.

HEARING CONSERVATION PROGRAM

Administration

This written hearing conservation plan serves as a record of the details of the hearing conservation program in place at this company. We have this program in place to protect the hearing of all workers in the company.

The Director of Safety has overall responsibility for coordinating safety and health programs in this company and is the person having overall responsibility for the Hearing Conservation Program. The Director of Safety will review and update the program, as necessary. Copies of the written program may be obtained at the office upon request.

Workers must wear hearing protection whenever they are exposed to noise levels above 90db.

Using the following examples of common construction tools, the Subcontractor's Foreman should be able to identify work areas that expose its subcontractor's employees to noise levels in excess of 90db.

Probable Noise Levels of Common Construction Tools

Noise levels represent exposures at operator's ear, except where otherwise indicated

Tool	Noise level will probably exceed...	Reference
Air compressor	90	CDC (2005)
Air hammer	110	Bragdon (1971)
Air track drill	110	Eaton (2000)
Asphalt grinder	111	Greenspan et al (1995)
Brick saw	94	Burgess and Lai (1999)
Chipper, pneumatic	100	Hassall (1979), Olishifski (1975)
Chipping gun	96	Kerr et al (2002), CDC (2005), UW (2004)
Chopsaw	92	Kerr et al (2002), UW (2004)
Compactor	90	Utley and Miller (1985)
Compressed air gun	104	Kerr et al (2002)
Concrete saw	98	CDC (2005)
Concrete vibrator	90	CDC (2005)
Cutoff saw	98	NZ DOSH (2002), Greenspan et al (1995)
Diesel hammer piledriver on concrete pile (at 15m)	95	Hong Kong EPD (1989)
Diesel hammer piledriver on steel pile (at 15m)	99	Hong Kong EPD (1989)
Drop hammer piledriver on steel pile (at 15m)	93	Hong Kong EPD (1989)
Electric grinder	98	NZ DOSH (2002)
Excavator	80	Greenspan et al (1995), Utley
Forklift	93	Utley and Miller (1985)
Front end loader	90	Burgess and Lai (1999), Utley and Miller (1985)
Grader/scrapper	107	Greenspan et al (1995)
Jackhammer	102	CDC (2005), Ren (1999), Alfredson and May (1978)
Jigsaw	91	NZ DOSH (2002), Kerr et al (2002)
Mechanical tamper	90	CDC (2005), Greenspan et al

		(1995)
Mechanical tamper at 50 ft	90	Alfredson and May (1978)
Nailgun	97	NZ DOSH (2002)
Paver at 50 ft	86	Alfredson and May (1978)
Piledriver at 50 ft	95	Alfredson and May (1978)
Powder actuated tool	89	NZ DOSH (2002), UW (2004), Kerr et al (2002)
Road grader	95	Dobie (1993)
Rotohammer	84	NZ DOSH (2002), CDC (2005), UW (2004), Kerr et al (2002)
Router	90	NZ DOSH (2002), Kerr et al (2002)
Scraper	117	Dobie (1993)
Stud welder	101	CDC (2005)
Welding equipment	92	UW (2004)

HEAT ILLNESS PREVENTION

Operations involving high air temperatures, radiant heat sources, high humidity, direct physical contact with hot objects, or strenuous physical activities have a high potential for inducing heat stress in employees engaged in such operations.

Outdoor operations conducted in hot weather, such as construction, especially those that require workers to wear semi permeable or impermeable protective clothing, are also likely to cause heat stress among exposed workers.

Causal factors

Age, weight, degree of physical fitness, degree of acclimatization, metabolism, use of alcohol or drugs, and a variety of medical conditions such as hypertension all affect a person's sensitivity to heat. However, even the type of clothing worn must be considered. Prior heat injury predisposes an individual to additional injury.

It is difficult to predict just who will be affected and when, because individual susceptibility varies. In addition, environmental factors include more than the ambient air temperature. Radiant heat, air movement, conduction, and relative humidity all affect an individual's response to heat.

Heat disorders and health effects

Heat stroke

Heat stroke occurs when the body's system of temperature regulation fails and body temperature rises to critical levels, this condition is caused by a combination of highly variable factors, and its occurrence is difficult to predict. Heat stroke is a medical emergency. The primary signs and symptoms of heat stroke are confusion; irrational behavior; loss of consciousness; convulsions; a lack of sweating (usually); hot, dry skin; and an abnormally high body temperature, e.g., a rectal temperature of 41C (105.8F). If body temperature is too high, it causes death. The elevated metabolic temperatures caused by a combination of work load and environmental heat load, both of which contribute to heat stroke, are also highly variable and difficult to predict.

If a worker shows signs of possible heat stroke, professional medical treatment should be obtained immediately. The worker should be placed in a shady area and the outer clothing should be removed. The worker's skin should be wetted and air movement around the worker should be increased to improve evaporative cooling until professional methods of cooling are initiated and the seriousness of the condition can be assessed.

Fluids should be replaced as soon as possible. The medical outcome of an episode of heat stroke depends on the victim's physical fitness and the timing and effectiveness of first aid treatment.

Regardless of the worker's protests, no employee suspected of being ill from heat stroke should be sent home or left unattended unless a physician has specifically approved such an order.

Heat exhaustion

The signs and symptoms of heat exhaustion are headache, nausea, vertigo, weakness, thirst, and giddiness. Fortunately, this condition responds readily to prompt treatment. Heat exhaustion should not be dismissed lightly, however, for several reasons. One is that the fainting associated with heat exhaustion can be dangerous because the victim may be operating machinery or controlling an operation that should not be left unattended; moreover, the victim may be injured when he or she faints. Also, the signs and symptoms seen in heat exhaustion are similar to those of heat stroke, a medical emergency.

Workers suffering from heat exhaustion should be removed from the hot environment and given fluid replacement. They should also be encouraged to get adequate rest.

Heat cramps

Heat cramps are usually caused by performing hard physical labor in a hot environment. These cramps have been attributed to an electrolyte imbalance caused by sweating. It is important to understand that cramps can be caused by both too much and too little salt. Cramps appear to be caused by the lack of water replenishment. Because sweat is a hypotonic solution ($\pm 0.3\%$ NaCl), excess salt can build up in the body if the water lost through sweating is not replaced. Thirst cannot be relied on as a guide to the need for water; instead, water must be taken every 15 to 20 minutes in hot environments.

Under extreme conditions, such as working for 6 to 8 hours in heavy protective gear, a loss of sodium may occur. Recent studies have shown that drinking commercially available carbohydrate-electrolyte replacement liquids is effective in minimizing physiological disturbances during recovery.

Heat collapse

In heat collapse (fainting), the brain does not receive enough oxygen because blood pools in the extremities. As a result, the exposed individual may lose consciousness. This reaction is similar to that of heat exhaustion and does not affect the body's heat balance. However, the onset of heat collapse is rapid and unpredictable. To prevent heat collapse, the worker should gradually become acclimatized to the hot environment.

Heat rashes

Heat rashes are the most common problem in hot work environments. Prickly heat is manifested as red papules and usually appears in areas where the clothing is restrictive. As sweating increases, these papules give rise to a prickling sensation. Prickly heat occurs in skin that is persistently wetted by un-evaporated sweat, and heat rash papules may become infected if they are not treated. In most cases, heat rashes will disappear when the affected individual returns to a cool environment.

Heat-fatigue

A factor that predisposes an individual to heat fatigue is lack of acclimatization. The use of a program of acclimatization and training for work in hot environments is advisable. The signs and symptoms of heat fatigue include impaired performance of skilled sensory motor, mental, or vigilance jobs. There is no treatment for heat fatigue except to remove the heat stress before a more serious heat-related condition develops.

Controls

Ventilation, air cooling, fans, shielding, and insulation are the five major types of engineering controls used to reduce heat stress in hot work environments. Heat reduction can also be achieved by using power assists and tools that reduce the physical demands placed on a worker.

However, for this approach to be successful, the metabolic effort required for the worker to use or operate these devices must be less than the effort required without them. Another method is to reduce the effort necessary to operate power assists. The worker should be allowed to take frequent rest breaks in a cooler environment.

Acclimatization

The human body can adapt to heat exposure to some extent. This physiological adaptation is called acclimatization. After a period of acclimatization, the same activity will produce fewer cardiovascular demands. The worker will sweat more efficiently (causing better evaporative cooling), and thus will more easily be able to maintain normal body temperatures.

A properly designed and applied acclimatization program decreases the risk of heat-related illnesses. Such a program basically involves exposing employees to work in a hot environment for progressively longer periods. NIOSH (1986) says that, for workers who have had previous experience in jobs where heat levels are high enough to produce heat stress, the regimen should be 50% exposure on day one, 60% on day two, 80% on day three, and 100% on day four. For new workers who will be similarly exposed, the regimen should be 20% on day one, with a 20% increase in exposure each additional day.

Fluid replacement

Cool (50-60F) water or any cool liquid (except alcoholic beverages) should be made available to workers to encourage them to drink small amounts frequently, e.g., one cup every 20 minutes. Ample supplies of liquids should be placed close to the work area. Although some commercial replacement drinks contain salt, this is not necessary for acclimatized individuals because most people add enough salt to their summer diets.

Worker monitoring programs

Every worker who works in extraordinary conditions that increase the risk of heat stress should be personally monitored. These conditions include wearing semi permeable or impermeable clothing when the temperature exceeds 21C (69.8F), working at extreme metabolic loads (greater than 500 kcal/hour), etc.

Respirator usage

The weight of a self-contained breathing apparatus (SCBA) increases stress on a worker, and this stress contributes to overall heat stress. Chemical protective clothing such as totally encapsulating chemical protection suits will also add to the heat stress problem.

The following administrative controls can be used to reduce heat stress:

- Reduce the physical demands of work, e.g., excessive lifting or digging with heavy objects;
- Provide recovery areas, e.g., air-conditioned enclosures and rooms;
- Use shifts, e.g., early morning, cool part of the day, or night work;
- Use intermittent rest periods with water breaks;
- Use relief workers;
- Use worker pacing; and **Circulating air**
- Assign extra workers and limit worker occupancy, or the number of workers present, especially in confined or enclosed spaces.

Responsibility

Subcontractors' are responsible for the following:

- Subcontractor's Forman shall ensure that drinking water is available in sufficient quantity at the beginning of each shift.
- Subcontractor's Foreman shall ensure that the water supply is checked frequently and replenished whenever the water containers are below half full.
- If a sweetener or flavoring is added to the water, Subcontractor's Foremen must have the approval of all crew members. If anyone on the crew objects to the added flavor or sweetener, it shall not be added or a second source of pure water must be provided.
- Subcontractor's Foremen shall ensure that shade is available as required in the regulations. (California job sites must have shade available for 25% of the crew at the beginning of the shift whenever the forecast is for temperatures of 85 degrees or higher.)

Training

Training in the following topics shall be provided to all supervisory and non-supervisory employees of LGC and Subcontractors.

- The environmental and personal risk factors for heat illness;
- The employer's procedures for complying with the requirements of this standard;
- The importance of frequent consumption of small quantities of water, up to 4 cups per hour, when the work environment is hot and employees are likely to be sweating more than usual in the performance of their duties;
- The importance of acclimatization;
- The different types of heat illness and the common signs and symptoms of heat illness;

- The importance to employees of immediately reporting to the employer, directly or through the employee's supervisor, symptoms or signs of heat illness in themselves, or in co-workers;
- The employer's procedures for responding to symptoms of possible heat illness, including how emergency medical services will be provided should they become necessary;
- The employer's procedures for contacting emergency medical services, and if necessary, for transporting employees to a point where they can be reached by an emergency medical service provider;
- The employer's procedures for ensuring that, in the event of an emergency, clear and precise directions to the work site can and will be provided as needed to emergency responders.
- Supervisor training. Prior to assignment to supervision of employees working in the heat, training on the following topics shall be provided:
 - The information outlined above.
 - The procedures the supervisor is to follow to implement the training required for all employees
 - The procedures the supervisor is to follow when an employee exhibits symptoms consistent with possible heat illness, including emergency response procedures.
 - The procedures the supervisor is to follow to implement the applicable provisions in this section.
 - The procedures the supervisor is to follow when an employee exhibits symptoms consistent with possible heat illness, including emergency response procedures.

Prevention Steps

- Drink plenty of Water/Electrolytes during the work day 3-4 (8) oz glasses
- Rest Breaks taken as needed during high heat days
- Take breaks in the shade or in cool areas
- Shade is a cool area with no direct sunlight for example an air conditioned vehicle.
- Wear light colored/cool clothing on hot days and change if perspiration accumulates
- Call 911 for any signs or symptoms of heat stroke or exhaustion.
- If you suspect heat illness, evaluate and treat the worker but do not allow them to go home without treatment or a period of evaluation.

Definitions of Heat Illness

Heat Cramps: Painful spasm of the muscles caused by losing salt and a lack of water. This usually occurs during hard physical labor like carrying material in high heat.

Treatment: Consume water, provide shade, and massage the cramp if the cramp is disabling, call 911.

Heat Exhaustion: Due to loss of fluid from sweating and not drinking water. Signs of heat exhaustion include cool, moist, pale flushed or red skin; heavy sweating; headache nausea vomiting, dizziness giddiness and extreme weakness or fatigue. The skin is clammy and moist while body temperature will be normal or slightly elevated.

Treatment: Cool the worker down; give them water or electrolytes and remove/loosen tight clothing and apply cold compresses. If they refuse fluids, vomit or lose consciousness, call 911.

Heat Syncope (Fainting): Workers not accustomed to the heat who stand for prolonged periods of time may faint. If a worker loses consciousness, call for care.

Treatment: Fainting is usually short lasting and will improve after lying down in a cool environment. If the fainting lasts for more than a minute, or is accompanied by changes in mental state, call 911.

Heat Stroke Symptoms: Victims of heat stroke can die unless treated.

- Hot, but not sweating
- Confusion, irrational behavior,
- Loss of consciousness, -Convulsions
- Hot, dry skin
- Body temperature (105.8F)

Treatment:

- Have the victim lie down in a shady area or get them indoors.
- Remove clothing and slowly apply cool water to the skin, fanning to stimulate sweating.
- Apply covered ice packs to the groin and armpits
- Heat Stroke victims must be transported for medical treatment immediately! (Call 911)

Awareness of heat illness symptoms can save your life or the life of a co-worker

- If you are coming back to work from an illness or an extended break or you are just starting a job working in the heat, it is important to be aware that you are more vulnerable to heat stress until your body has time to adjust. Let your employer know you are not used to the heat. It takes about 5 – 7 days for your body to adjust.
- Drinking plenty of water frequently is vital to workers exposed to the heat. An individual may produce as much as 2 to 3 gallons of sweat per day. In order to replenish that fluid the worker should drink 3 to 4 cups of water every hour starting at the beginning of your shift.
- Taking your breaks in a cool shaded area and allowing time for recovery from the heat during the day are effective ways to avoid heat illness.

- Avoid or limit the use of alcohol and caffeine during periods of extreme heat. Both dehydrate the body.
- If you or a co-worker start to feel symptoms such as nausea, dizziness, weakness or unusual fatigue, let your supervisor know and rest in a cool shaded area. If symptoms persist or worsen seek immediate medical attention.
- Whenever possible, wear clothing that provides protection from the sun but allows airflow to the body. Protect your head and shade your eyes if working outdoors.
- When working in the heat be sure to pay extra attention to your coworkers and be sure you know how to call for medical attention.

In any and all cases of illness or accidental injury, contact the emergency services in your area as per your assigned emergency action plan. Immediately report all incidents to Rob Plavajka at (949) 474.0221.

HOUSEKEEPING

INTRODUCTION

Housekeeping on a construction site means working in a manner that reduces waste and eliminates accumulation of waste materials from one day to the next. All waste materials should be collected daily and staged in a specific location that does not pose a hazard to other workers.

ACCOUNTABILITY

The condition of the work-zone is the responsibility of any and all LGC Superintendents on the job-site. Subcontractors will be held accountable for the accumulation of waste material in the work zone or improper disposal or storage of waste material.

If the LGC Superintendent deems the projects accumulation of waste adversely affects work operations, they are required to notify the Subcontractor responsible for clean up. If the Superintendent does not find site conditions improved, they are hereby directed to photograph the affected area and contact the LGC Director of Safety: Rob Plavajka **(949) 474.0221**.

HOUSEKEEPING BEST PRACTICES

1. During the course of construction, alteration, or repairs, form and scrap lumber with protruding nails and all other debris shall be kept reasonably cleared from work areas, passageways, and stairs in and around buildings or other structures. (To include scrap rebar and tie wire.)
2. Material storage areas and walkways on the construction site shall be maintained reasonably free of dangerous depressions, obstructions, and debris.
3. Combustible debris accumulated within the building or structure shall be removed promptly during the course of construction. Safe means shall be provided to expedite such removal.
4. Flammable or hazardous wastes shall be placed in covered containers separate from the normal debris.
5. All waste shall be disposed of at intervals determined by the rate of accumulation and capacity of the job site container.
6. Waste, materials, or tools shall **not be thrown** from buildings or structures to areas where employee(s) may be located, unless the area where the material falls is guarded by fences, barricades, or other methods/means to prevent employee(s) from entering and being struck by falling objects. Signs shall be posted to warn employees of the hazard.

LOCK-OUT/TAG-OUT

PURPOSE

This program establishes the minimum requirements for the lockout of energy sources. It shall be used to ensure that, before an employee performs any servicing or maintenance activities where the unexpected energization, start-up or release of stored energy could occur and cause injury, all potentially hazardous energy shall be locked out.

Potentially hazardous energy means mechanical energy due to pressure, gravity, or springs; electrical energy; and thermal energy (heat or cold). These procedures will help make sure that anyone working on equipment isn't electrocuted, hit, cut, crushed or otherwise hurt during repair or service.

INTRODUCTION

Failure to lock out and block out machinery before working on it is a major cause of serious injury and death.

Workers are electrocuted—or lose fingers, hands, arms—or suffer severe crushing injuries—because machinery is inadvertently turned on while it is being maintained, repaired or adjusted. These injuries can be prevented by establishing and using an effective lockout program.

To prevent these kinds of lockout/tagout accidents, OSHA Regulations —requires every employer to inaugurate and maintain an accident prevention program which shall include but not be limited to the following:

1. A training program designed to instruct employees in general safe work practices, plus specific instruction with regard to hazards unique to any job assignment.
2. Scheduled periodic inspections to identify and correct any unsafe conditions and work practices that may be found.
3. The employer shall correct unsafe conditions and work practices found as a result of the required inspections.

To be effective, a lockout/tagout program should include:

- A survey of the equipment by responsible persons who are thoroughly familiar with its operation and associated hazards, in order to identify which machinery should be locked and blocked out.
- Identification and labeling of lockout devices. Selection and purchase of locks, tags and blocks.
- A standard operating procedure that is written and followed.

RESPONSIBILITY

All LGC and Subcontractors employees shall be instructed in the safety significance of lockout procedures by their Safety Representative. Each new or transferred affected employee shall also be trained in the purpose and use of the lockout procedure. Authorized employees shall receive the training required to safely lock and tag equipment out of service.

TRAINING

It is company policy that all exposed employees of LGC and Subcontractor's employees will be trained in the following:

- a. New employees will be trained in Lockout/Tagout procedures prior to engaging in activities that require lockout to ensure safety.
- b. Current employees will be retrained when new equipment and lockout procedures are introduced into the workplace.
- c. The recognition of hazardous energy sources.
- d. The type and magnitude of the energy available in the workplace.
- e. The method and means necessary for energy isolation and control

Equipment Survey:

Identifying & Labeling the Energy Disconnecting Means

Make an initial survey of the plant or operation to identify all energy sources. This must be done by physical inspection, possibly in combination with a study of drawings and equipment manuals.

Locate and mark the disconnecting means, indicating their function. Categorize the identification details as to equipment supplied and energy type and magnitude, from material worked out beforehand in this lockout/tagout program planning study.

Methods of Locking Out Controls

There are many different ways to lock out a piece of equipment. Commonly, the main disconnect switch has one opening where a lock can be placed.

If more than one employee works on the equipment, a lockout adaptor suitable for the installation of several locks must be used, enabling all workers to lock out the machine with their individual locks.

If the switches are in a metal box, the box itself must be locked out.

If a fuse was removed in order to de-energize the equipment, the fuse box must be locked.

If the controls are in a metal-covered box, a common hasp can be welded or riveted to the door, along with a lock staple. Then the switch can be "opened" and the door closed and padlocked.

Fuse boxes can also be locked in this way.

Machines activated by compressed air or steam will have valves that control movement. These valves will need not only to be locked out, but also bled to release any back pressure.

Lockout Procedure Requirements

1. All Authorized personnel are issued a suitable lock (or locks). The lock has the individual worker's name and other identification on it. Each worker has the only key to their lock.
2. The worker checks to be sure that no one is operating the machinery BEFORE turning off the power. The machine operator is informed before the power is turned off. Sudden loss of power could cause an accident. All affected employees are notified prior to LOTO.
3. Steam, air, and hydraulic lines should be bled, drained, and cleaned out. There should be no pressure in these lines or in reservoir tanks.
4. Any mechanism under load or pressure, such as springs, should be released and blocked.
5. Each person who will be working on the machinery should put a lock on the machine's lockout device(s). Each lock must remain on the machine until the work is completed. Only the worker who placed the lock should remove his/her lock.
6. All energy sources which could activate the machine must be locked out. The main valve or main electrical disconnect must be tested to be sure that the power to the machine is off.
7. Electrical circuits must be checked by qualified persons with proper and calibrated electrical testing equipment. An electrical failure could energize the equipment, even if the switch is in the off position. Stored energy in electrical capacitors should be safely discharged.

CAUTION: Return disconnects and operating controls to the off position after each test.

Attach accident prevention tags which give the reason for placing the tag, the name of the person placing the tag, how he/she may be contacted, and the date and time the tag was placed. No one removes the lock without proper authority.

Locks, Blocks, & Accident Prevention Tags

Locks

Each worker must have his/her own lock and the only key to that lock.

The lock should be substantial and durable, and should have the name of the employee on it. In addition, locks can be color-coded to indicate different shifts or types of crafts.

When more than one worker is servicing a piece of equipment that must be locked out, a lockout adapter can be used which allows all the workers to place their locks on the disconnecting means. After the work is completed, each worker removes his/her lock and the machine is then returned to service.

Tags

DO NOT USE TAGS ALONE. Exception: Cord & plug equipment where the Authorized Employee tagging the equipment maintains control of the cord & plug.

Tags must state the:

- reason for the lockout.
- name of the employee who is working on the equipment and how that person may be reached.
- date and time the tag was put in place.

Tagout devices shall be capable of enduring at least 50 pounds of pull, and a non-reusable type.

Blocks

Suitable blocks are another important safety device for making a piece of equipment safe to be repaired or serviced. Blocks must be placed under raised dies, lifts, or any equipment that might inadvertently move by sliding, falling or rolling.

Blocks, special brackets, or special stands such as those commonly used under raised vehicles, must be available and always used. Another form of blocking is the placement of a blind. A blind is a disk of metal placed in a pipe to ensure that no air, steam, or other substance will pass through that point if the system is accidentally activated.

Before installing blinds or blocks, bleed down steam, air, or hydraulic lines to get rid of any pressure. Coiled springs, spring-loaded devices, or suspended loads must also be released so that their stored energy will not result in inadvertent movement.

Written Standard Operating Procedure

A lockout usually requires coordination between the General Contractor and Subcontractor. The best way to put into practice an effective lockout program is to first prepare a written, standardized operating procedure, then carry out the necessary training and responsible supervision.

In a check list format, prepare a written sequence for access, de-energizing, lockout, clearance, release, and start-up.

Also consider stored energy. Conditions not hazardous during normal operations can become hazardous when guards are removed during maintenance and servicing.

In writing a lockout procedure, consider:

- job objectives and equipment involved.
- detailing the energy sources for each machine and lockout procedures. steps for shutting down and securing machinery.
- steps to verify lockout effectiveness.
- procedural steps for applying lockout and tagout.
- procedural steps for restarting.
- employees authorized to perform lockout.

In training for lockout procedure, consider:

- Employees must understand what equipment tagout means, and what to do if they want to operate it.
- The authorized person must be trained in written procedure and fully knowledgeable of hazardous energies specifically related to equipment.
- Employees reassigned to different equipment must be retrained.
- Subcontractors working on site must have a general understanding of lockout/tagout and follow the employer's procedures.

Testing Equipment During Lockout

In many maintenance and repair operations, machinery may need to be tested—and for that purpose, energized before additional maintenance work can be performed.

This procedure must be followed:

1. Clear all personnel to safety.
2. Clear away tools and materials from equipment.
3. Remove lockout devices and re-energize systems, following the established safe procedure.
4. Proceed with tryout or test.
5. Neutralize all energy sources once again, purge all systems, and lockout prior to continuing work.

Equipment design and performance limitations may dictate that effective alternative worker protection be provided when the established lockout procedure is not feasible.

If machinery must be capable of movement in order to perform a maintenance task, such as a cleaning operation, workers can use extension tools—extended swabs, brushes, scrapers—to protect themselves from injury.

Restoring Equipment to Service

After the work is completed and the equipment is ready to be returned to normal operation, this procedure must be followed:

1. Remove all non-essential items.
2. See that all equipment components are operationally intact, including guards and safety devices.
3. Repair or replace defective guards before removing lockouts.
4. Remove each lockout device using the correct removal sequence.
5. Make a visual check before restoring energy to ensure that everyone is physically clear of the equipment.
6. Notify affected employees that the equipment has been restored to service.

PERSONAL PROTECTIVE EQUIPMENT

ACCOUNTABILITY

LGC Superintendent's have the responsibility for ensuring that the Subcontractor's are protected from hazards at their jobsite. Through pre-project planning and pre-task planning and job safety analysis (JSA) the Subcontractor's foreman should be able to identify the necessary PPE requirements for the tasks to be performed.

Subcontractor's Foremen must constantly be observing their employees to ensure compliance with the minimum safety policy and standards. Field and shop/yard workers are required to wear the following minimum equipment at all times while working: (contractors may require additional PPE) Visitors will be provided safety glasses, earplugs and hardhats before entering any jobsite.

1. Hardhat (mandatory)
2. Safety Glasses
3. Boots
4. Shirt (long/short sleeve)
5. Pants (no shorts)
6. Gloves (when required)
7. Safety Vest/ High Visibility Shirt (when required)
8. Hearing Protection – earplugs (when required)
9. Respiratory Protection (when required)

EYE AND FACE PROTECTION

Subcontractor employees that are exposed to light radiation, i.e. cutting/welding, during the course of his/her workday shall use eye protection with filter lenses having a shade number appropriate for the work being performed.

Secondary protection such as face shields is required in conjunction with Safety Glasses & Goggles during severe exposure to impact hazards.

Employees wearing face protection must also wear eye protection underneath. Splash goggles are required where the employee is exposed to any liquid chemicals, acids, or caustics.

POST TENSIONING

INTRODUCTION

Post-tensioning is a method of reinforcing (strengthening) concrete or other materials with high-strength steel strand or bars, typically referred to as tendons. The tension applied to the strands and the couplings results in tremendous kinetic energy. If this energy is accidentally released, serious injuries and or property damage could result. LGC has developed this policy to reduce risks associated with Post Tensioning operations.

ACCOUNTABILITY

Subcontractor's Foreman

The Subcontractor's foreman is directly responsible for ensuring the safe execution of Post Tensioning Operations. All personnel performing the tensioning must be qualified to do so or may be in training only under a qualified person supervised by the Subcontractor's foreman.

LGC and Subcontractor's employees shall abide by the policies and procedures as outlined in the Post-Tensioning Manual. Only trained and authorized employees shall conduct Post-Tensioning operations.

Post Tensioning Best Practices

1. Signs and/or barriers shall be erected to limit employee access to the post-tensioning area during tensioning operations.
2. No employee shall be permitted to be behind the jack during tensioning operations.
3. Tensioning operations shall be under the immediate control of a person experienced in such operations.
4. Do not stand over, in front of, or behind the jack during stressing. Watch the pressure gauge at all times. - Do not over stress the tendon.
5. To prevent injury, stay clear of the jack movement at "all times, especially while cylinders are retracting. Do not over-close the jack. Excessive pressure on the return side may cause the pump to explode, injuring the user.
6. Do not over-pressure the jack after the cylinder is completely extended. Do not exceed the required gauge pressure.
7. Check stressing jack prior to use. Make sure the equipment is clean, especially the jack grippers and the nose seating area. Follow all instructions provided by supplier.
8. Check inside of each anchor cavity, making sure that the exposed portion of the anchor is clean. Remove any concrete film or paste with a scraper or screwdriver. This will eliminate slippage and excessive seating loss.
9. Never beat on the ram if it becomes hung-up.
10. If elongation measurements are not accurate, DO NOT stress more tendons until the problem is identified and corrected.
11. When burning tails, do not direct flame onto wedges. This may cause cable to retract, causing injury. Never use the tensioning machine for anything other than its intended use.
12. Never use the tensioning machine for anything other than its intended use.
13. Do not wipe excess grease on forms, or other work surfaces. Use rags and dispose of them properly.
14. A standing area, with guardrail, shall be provided for the employees stressing cables, the stressing equipment shall be secured during operation.
15. Workers directly involved in stressing operations must wear safety glasses or goggles.

De-Stressing Procedures

Only trained and authorized Subcontractor employees shall be involved in de-stressing / de-tensioning operations. The jobsite Subcontractor's supervisor shall prepare a job site specific hazard analysis, for the de-tensioning work to be done using the information provided by the PT Consultant/Engineer.

POWERED INDUSTRIAL TRUCK PROGRAM (Forklift)

INTRODUCTION

Lucas General Contracting has developed a Powered Industrial Truck (PIT) Program to minimize the risk of worker injury and property damage from the use of Powered Industrial Trucks.

APPLICABILITY/SCOPE

A Powered Industrial Truck is defined as a fork truck, platform lift truck, motorized hand truck, and other specialized industrial truck powered electric motors or internal combustion engines.

This section of the LGC Safety Manual is not intended to replace the required training and certification required by each of the Subcontractor's and vendor's contracted by LGC.

ACCOUNTABILITY

Superintendent/Subcontractor's Foreman

- Ensure that all PIT operators have been trained and are authorized to operate
- Ensure equipment has been inspected and maintained
- Ensure that operators are following all operating procedures.
- Ensure that any PIT operator observed driving in an unsafe manner is removed until retraining is conducted.

Operator

- Make available a copy of PIT certification
- Follow operating procedures at all times
- Visually inspect your equipment each day and prior to each use
- Know the weight of the item you are lifting

Training

Under no circumstances shall an LGC or Subcontractor's employee operate a powered industrial truck/forklift until he/she has successfully completed Lucas General Contracting's, forklift operation training program.

Training must consist of a combination of formal instruction and practical training. Formal instruction may include lectures, conferences, classroom discussions, demonstrations, and written or oral tests.

Refresher Training

Once every 3 years an evaluation should be conducted of each powered industrial truck operator's performance should be provided.

Best Practices

Powered Industrial Trucks

1. Passengers are not allowed to ride on powered industrial trucks.
2. Operators shall not block access to fire or emergency exits, stairways, fire equipment, or electrical panels.
3. Under all travel conditions; operate the truck at a speed that will permit it to be brought to a stop in a safe manner.
4. The capacity rating of the truck should be clearly identified on the exterior.
5. The operator shall know the weight of the load and the rating of the PIT.
6. The operator shall look 360 degrees when moving a lift truck.
7. Operators shall slow down and sound the horn where vision is obstructed.
8. The operator must keep a clear view of the path of travel and observe for other traffic, personnel and safe clearances. If the load being carried obstructs forward view, travel with the load trailing (except when ascending a ramp or entering a trailer).
9. When the forks are empty, the operator shall travel with the forks at a negative pitch as low to the floor as practical. The operator is responsible for adjusting the height of the forks to a safe level when the operating terrain warrants.
10. When traveling with a load on the forks, the operator shall travel with the load as low to the floor as practical with the load tilted slightly for improved stability.
11. Personnel shall not be allowed to stand, pass, or work under the elevated portion of any industrial truck, loaded or empty, unless it is effectively blocked to prevent it from falling.
12. A powered industrial is considered to be ATTENDED when the operator is less than 25 feet from the truck, which remains in his view. Before leaving the operator's position, the operator shall:
 - Bring truck to a complete stop.
 - Place directional controls in neutral.
 - Apply the parking brake.
 - Lower the forks or attachments fully until resting completely flat on the floor. When lowering unloaded forks, the forks shall be tilted forward first and then lowered to the ground until the tips of the forks come in contact with the floor.
13. A powered industrial truck is considered to be UNATTENDED when the operator is more than 25 feet from the truck which remains in his view. Or whenever the operator leaves the truck and it is not in view regardless of distance from the truck. Before leaving the operator's position:
 - Follow the procedures in item above
 - Stop the engine or turn off the controls
14. To change an LP gas tank, the operator shall:
 - Put on leather work gloves and goggles.
 - Disconnect lift truck valve from the empty LP cylinder.
 - Replace with full cylinder.
 - The pin on the lift truck must fit into the cut hole(s) provided on the gas cylinder. **THIS IS REQUIRED BY LAW.**
 - Strap in the cylinder and reconnect the truck valve securely to the cylinder in the outlet.
 - Open cylinder valve for leaks.

- If leaking, close cylinder valve and slowly uncouple the fuel valve. Try to reconnect. If still leaking, try a different cylinder and notify shift leader or department management of faulty cylinder.
- If no leaks are present, lift truck may be utilized.
- Lift trucks shall not be operated with a leak in the fuel system until the leak has been corrected.

15. The operator shall use the following procedure to travel in reverse:

- Pivot at the waist and inspect the area of operation in the rear of the fork truck. Watching for obstructions and pedestrians.
- Blow the horn to alert any pedestrians that may or may not be visible.
- Engage the directional lever to reverse position.
- Concentrate on the removal of the forks from the load to avoid any load disturbance, as you back the fork truck out of the load.
- Stop the fork truck 18"-24" away from the loads resting location and lower the forks to the proper travel height and angle.

16. During load placement, the operator shall:

- Square the fork truck with the load resting location.
- Stop the fork truck 18" to 24" away from the load resting location.
- Raise the load to proper entry height.
- Drive forward with the load and position the load over its resting location.
- Lower the load to a height of 4" if possible.
- Tilt the load forward to a level position.
- Lower the load to its resting position.
- Back up the unit using proper back up procedures and sequence.

17. During load retrieving, the operator shall:

- Square the fork with the load resting location.
- Stop the fork 18" to 24" away from the load resting location.
- Raise the forks to the proper entry height.
- Enter the load and maintain the clearance around the forks to avoid load disturbance.
- Raise the load so it is completely suspended from its resting platform.
- Tilt the load back.
- Visually inspect the rear area of the fork truck to ensure no pedestrians are behind or around the unit.
- Back up the unit using proper back up procedures and sequence.
- Back up the fork truck 18" to 24" and stop.
- Lower the load to the proper travel height.

RESPIRATORY PROTECTION PROGRAM

PURPOSE

The purpose of this respirator program is to establish standard operating procedures to ensure the protection of all employees from respiratory hazards through proper selection and use of respirators. This program applies to all LGC and Subcontractor's employees who are required to wear respirators during normal operations, non-routine tasks, or emergency operations such as a spill of a hazardous substance.

RESPONSIBILITIES

- Identifying work areas, processes or tasks that require workers to wear respirators, and evaluating hazards
- Selection of respiratory protection options
- Monitoring respirator use to ensure that respirators are used in accordance with their certifications
- Arranging for and/or conducting training
- Ensuring proper storage and maintenance of respiratory protection equipment
- Conducting or arranging for fit testing
- Administering the medical surveillance program
- Maintaining records required by the program
- Evaluating the program
- Updating written program as needed

Supervisors Duties

Supervisors are responsible for ensuring that the respiratory protection program is implemented in their particular areas. In addition to being knowledgeable about the program requirements for their own protection, supervisors must also ensure that the program is understood and followed by the employees under their charge. Duties of the supervisor include:

- Ensuring that employees under their supervision (including new hires) have received appropriate training, fit testing, and medical evaluation
- Ensuring the availability of appropriate respirators and accessories
- Being aware of tasks requiring the use of respiratory protection
- Enforcing the proper use of respiratory protection when necessary
- Ensuring that respirators are properly cleaned, maintained, and stored according to the respiratory protection plan
- Ensuring that respirators fit well and do not cause discomfort
- Continually monitoring work areas and operations to identify respiratory hazards
- Coordinating with the program administrator on how to address respiratory hazards or other concerns regarding the program

Employees Duties

Each employee has the responsibility to wear his or her respirator when and where required and in the manner in which they were trained. Employees must also:

- Care for and maintain their respirators as instructed and store them in a clean sanitary location
- Inform their supervisor if the respirator no longer fits well, and request a new one that fits properly
- Inform their supervisor of any respiratory hazards that they feel may not be adequately addressed in the workplace and of any other concerns that they have regarding the program

PROGRAM ELEMENTS

Respirator Selection

Respirators are selected on the basis of the hazards to which the employees are exposed and in accordance with OSHA requirements. Only NIOSH certified respirators will be selected and used.

The Subcontractor's will conduct a hazard evaluation for each operation process, or work area where airborne contaminants may be present in routine operations or during an emergency. **The hazard evaluation will include:**

- Identification of the hazardous substances used in the workplace, department or work process;
- Review of work processes to determine where potential exposures to these hazardous substances may occur; and
- Exposure monitoring to quantify potential hazardous exposures.

The results of any hazard evaluation should be provided to the Superintendent to be located in the construction office for review.

The Subcontractor's will revise and update the hazard assessment as needed (i.e., any time work process changes which may potentially affect exposure).

General requirements

- Subcontractor's shall select and provide an appropriate respirator based on the respiratory hazard(s) to which the worker is exposed to in the workplace and user factors that affect respirator performance and reliability.
- Subcontractor's shall select a NIOSH-certified respirator. The respirator shall be used in compliance with the conditions of its certification.
- Subcontractor's shall identify and evaluate the respiratory hazard(s) in the workplace; this evaluation shall include a reasonable estimate of employee exposures to respiratory hazard(s) and an identification of the contaminant's chemical state and physical form. Where the employer cannot identify or reasonably estimate the employee exposure, the employer shall consider the atmosphere to be IDLH.
- Subcontractor's shall select respirators from a sufficient number of respirator models and sizes so that the respirator is acceptable to, and correctly fits, the user.

Respirators for Immediately Dangerous to Life and Health (IDLH) atmospheres

- Subcontractor's shall provide the following respirators for their employee use in IDLH atmospheres:
 - A full facepiece pressure demand SCBA certified by NIOSH for a minimum service life of thirty minutes, or
 - A combination full facepiece pressure demand supplied-air respirator (SAR) with auxiliary self contained air supply.
- Respirators provided only for escape from IDLH atmospheres shall be NIOSH-certified for escape from the atmosphere in which they will be used .
- All oxygen-deficient atmospheres shall be considered IDLH. Exception: If the employer demonstrates that, under all foreseeable conditions, the oxygen concentration can be maintained within the ranges specified in Table II of this section [29 CFR 1910.134(d), i.e., for the altitudes set out in the table], then any atmosphere-supplying respirator may be used.

Respirators for atmospheres that are not IDLH

Subcontractors shall have a respirator that is adequate to protect the health of their employees and ensure compliance with all other OSHA statutory and regulatory requirements, under routine and reasonably foreseeable emergency situations.

NIOSH Certification

All respirators must be certified by the National Institute for Occupational Safety and Health (NIOSH) and shall be used in accordance with the terms of that certification. Also, all filters, cartridges, and canisters must be labeled with the appropriate NIOSH approval label. The label must not be removed or defaced while it is in use.

Voluntary Respirator Usage

Subcontractors will provide all their employees who voluntarily choose to wear either of the above respirators with a copy of Appendix D of the standard. (Appendix D details the requirements for voluntary use of respirators by employees.) Employees choosing to wear a half facepiece air purifying respirators (APR) must comply with the procedures for medical evaluation, respirator use, and cleaning, maintenance and storage.

Subcontractors shall authorize voluntary use of respiratory protective equipment as requested by all other workers on a case-by-case basis, depending on specific workplace conditions.

Respirator Filter & Canister Replacement/Change Schedule

An important part of the Respiratory Protection Program includes identifying the useful life of canisters and filters used on air purifying respirators. Each filter and canister shall be equipped with an end-of-service-life indicator (ESLI) certified by NIOSH for the contaminant; or

If there is no ESLI appropriate for conditions a change schedule for canisters and cartridges that is based on objective information or data that will ensure that canisters and cartridges are changed before the end of their service life.

Cartridges/Filters shall be changed-based on the most limiting factor below:

- Prior to expiration date
- Manufacturer's recommendations for use and environment
- After each use
- When requested by employee
- When restriction to air flow has occurred as evidenced by increased effort by user to breathe normally

Medical Evaluation

Employees who are required to wear respirators must be medically evaluated before being permitted to wear a respirator on the job. Employees are not permitted to wear respirators until a physician has determined that they are medically able to do so.

A licensed health care professional who is part of our network of medical providers will provide the medical evaluation to employees. Medical evaluation procedures are as follows:

- The medical evaluation will be conducted using medical questionnaire provided in Appendix C of 29 CFR 1910.134 Respiratory Protection Standard. The Safety Department will provide a copy of this questionnaire to all employees requiring medical evaluation.
- To the extent feasible, the company will assist employees who are unable to read the questionnaire. When this is not possible the employee will be sent directly to the health care professional for assistance and medical evaluation.
- All affected employees will be given a copy of the medical questionnaire to fill out, along with a stamped and addressed envelop for mailing the questionnaire to the health care professional. Employees will be permitted to fill out the questionnaire on company time.
- Follow up medical exams will be provided to employees as required by the OSHA standard, and/or as deemed necessary by the health care professional.
- All employees will be allowed the opportunity to speak with the health care professional about their medical evaluation if they so request.
- The program administrator will provide the health care professional with a copy of this program and a copy of OSHA's respiratory protection standard. For each employee requiring evaluation, the health care professional will be provided with information regarding the employee's work area or job title, proposed respirator type and weight, length of time required to wear the respirator, expected physical work load (light, moderate, or heavy), potential temperature and humidity extremes, and any additional protective clothing required.
- After an employee has received clearance to wear a respirator, additional medical evaluations will be provided under any of the following circumstances:
 - The employee reports signs and/or symptoms related to their ability to use a respirator, such as shortness of breath, dizziness, chest pains, or wheezing;
 - The health care professional or supervisor informs the Program Administrator that the employees need to be reevaluated;
 - Information from this program, including observations made during fit testing and program evaluation, indicates a need for reevaluation; and
 - A change occurs in workplace conditions that may result in an increased physiological burden on the employee.

NOTE: All examinations and questionnaires are to remain confidential between the employee and the physician.

Fit Testing Procedures

The Medical Clinic Selected will ensure that fit-test will be administered using an OSHA-accepted qualitative fit test (QLFT) or quantitative fit test (QNFT) protocol. The OSHA-accepted QLFT and QNFT protocols are contained in Appendix A of the Respiratory Standard (1910.134).

Lucas General Contracting and Subcontractor's employees to be fit tested at the following times and with the same make, model, style, and size of respirator that they will be using.

- Before being allowed to wear any respirator with a tight-fitting face piece and at least annually thereafter;
- Whenever a different respirator face piece (size, style, model, or make) is used;
- Whenever visual observations of changes in the employee's physical condition that could affect respirator fit. Such conditions include, but are not limited to, facial scarring, dental changes, cosmetic surgery, or an obvious change in body weight; and
- Upon employee notification that the fit of the respirator is unacceptable.

The employer must establish a record of the fit tests administered to employees including:

- The name or identification of the employee tested;
- Type of fit test performed;
- Specific make, model, style, and size of respirator tested;
- Date of test; and
- The pass/fail results

The individual who uses a tight-fitting respirator is to perform a user seal check to ensure that an adequate seal is achieved each time the respirator is put on. Either the positive and negative pressure checks listed in this appendix, or the respirator manufacturers recommended user seal check method shall be used. User seal checks are not substitutes for qualitative or quantitative fit tests.

Face piece Positive and/or Negative Pressure Checks

A. Positive pressure check. Close off the exhalation valve and exhale gently into the face piece. The face fit is considered satisfactory if a slight positive pressure can be built up inside the face piece without any evidence of outward leakage of air at the seal. For most respirators this method of leak testing requires the wearer to first remove the exhalation valve cover before closing off the exhalation valve and then carefully replacing it after the test.

B. Negative pressure check. Close off the inlet opening of the canister or cartridge(s) by covering with the palm of the hand(s) or by replacing the filter seal(s), inhale gently so that the face piece collapses slightly, and hold the breath for ten seconds. The design of the inlet opening of some cartridges cannot be effectively covered with the palm of the hand. The test can be performed by covering the inlet opening of the cartridge with a thin latex or nitrile glove. If the face piece remains in its slightly collapsed condition and no inward leakage of air is detected, the tightness of the respirator is considered satisfactory.

Manufacturer's Recommended User Seal Check Procedures

The respirator manufacturer's recommended procedures for performing a user seal check may be used instead of the positive and/or negative pressure check procedures provided that the employer demonstrates that the manufacturer's procedures are equally effective.

USE OF RESPIRATORS

General Use Procedures

LGC and Subcontractor's employees will use their respirators under conditions specified by this program, and in accordance with the training they receive on the use of each particular model. In addition, the respirator shall not be used in a manner for which it is not certified by NIOSH or its manufacturer.

All employees shall conduct user seal checks each time that they wear their respirator. Employees shall use either the positive or negative pressure check (depending on which test works best for them) specified in Appendix B-1 of the Respiratory Protection Standard.

All employees shall be permitted to leave the work area to maintain their respirator for the following reasons: to clean their respirator if the respirator is impeding their ability to work, change filters or cartridges, replace parts, or to inspect respirator if it stops functioning as intended. Employees should notify their supervisor before leaving the area.

Employees are not permitted to wear tight fitting respirators if they have any condition, such as facial hair, facial scars, or missing dentures that prevents them from achieving a good seal. Employees are not permitted to wear headphones, jewelry, or other articles that may interfere with the facepiece to face seal.

Dust Masks

Employees who voluntarily use dust masks (N95 non-valve type only) will not be required to complete a medical review or respirator training. However, anyone using a dust mask must be trained to wear it correctly and understand the purpose and limits of use.

Dust masks may only be used in environments where airborne contaminants are below OSHA exposure limits (PELs) and exposure is only to non-toxic nuisance material.

Emergency Procedures

- There are no areas identified at our company that require Emergency Escape respirators.

Immediately Dangerous to Life or Health (IDLH) Procedures

- There are no areas identified at our company that contain IDLH atmospheres and procedures are not necessary at this time.

Respirator Malfunction

For any malfunction of a respirator (e.g., such a breakthrough, facepiece leakage, or improperly working valve), the respirator wearer should inform his or her supervisor that the respirator no longer functions as intended, and go to a safe area to maintain the respirator. The supervisor must ensure that the employee receives the needed parts to repair the respirator, or is provided with a new respirator.

Maintenance and Care Procedures

In order to ensure continuing protection from the respirators being use, it is necessary to establish and implement proper maintenance and care procedures and schedules. A lax attitude toward maintenance and care will negate successful selection and fit because the devices will not deliver the assumed protection unless they are kept in good working order.

Cleaning & Disinfecting

Our company provides each respirator user with a respirator that is clean, sanitary, and in good working order. We ensure that respirators are cleaned and disinfected weekly or as often as necessary to be maintained in a sanitary condition. Respirators are cleaned and disinfected using the procedures specified per manufacturer recommendations.

Respirators are cleaned and disinfected:

- As often as necessary when issued for the exclusive use of one employee;
- Before being worn by different individuals;
- After each use for emergency use respirators; and
- After each use for respirators used for fit testing and training.

Storage

Storage of respirators must be done properly to ensure that the equipment is protected and not subject to environmental conditions that may cause deterioration. We ensure that respirators are stored to protect them from damage, contamination, dust, sunlight, extreme temperatures, excessive moisture, and damaging chemicals. They are packed and stored by each user in accordance with any applicable manufacturer's instructions.

Respirator Inspection

All respirators will be inspected after each use and at least monthly. Should any defects be noted, the respirators will be taken to the program administrator or supervisor. Damaged respirators will be either repaired or replaced.

Respirators shall be inspected as follows:

- All respirators used in routine situations shall be inspected before each use and during cleaning;
- All respirators maintained for use in emergency situations shall be inspected at least monthly and in accordance with manufacturer's recommendations, and shall be checked for proper function before and after each use; and
- Emergency escape-only respirators shall be inspected before being carried into the workplace for use.

Respirator inspections shall include the following:

- A check of respirator function, tightness of connections, and the condition of the various parts including, but not limited to, the facepiece, head straps, valves, connecting tube, and cartridges, canisters or filters; and
- Check of elastomeric parts for pliability and signs of deterioration.

The following checklist will be used when inspecting respirators:

- **Facepiece:** cracks, tears, or holes, facemask distortion, cracked or loose lenses/faceshield
- **Headstraps:** breaks or tears, broken buckles
- **Valves:** residue or dirt, cracks or tears in valve material
- **Filters/Cartridges:** approval designation, gaskets, cracks or dents in housing, proper cartridge for hazard
- **Air Supply Systems:** breathing air quality/grade, condition of supply hoses, hose connections, settings on regulators and valves

Training

The Safety Department will be responsible to provide respirator training for respirator users or their supervisors on the contents of the Respiratory Protection Program and their responsibilities under it, and on the OSHA Respiratory Protection Standard. Workers will be trained prior to using a respirator in the workplace. Supervisors will also be trained prior to using a respirator in the workplace or prior to supervision of employees that must wear respirators.

The training will cover the following topics:

- The OSHA Respiratory Protection Standard
- Respiratory hazards encountered and their health effects
- Proper selection and use of respirators
- Limitations of respirators
- Respirator donning and user seal (fit) checks
- Fit testing
- Emergency use procedures
- Maintenance and storage
- Medical signs and symptoms limiting the effective use of respirators

Employees will be retrained annually or as needed (e.g., if they need to use a different respirator). Employees must demonstrate their understanding of the topics covered in the training utilizing a hands-on exercise and a written test. Respirator training must be documented by the Subcontractors and the documentation will include the type, model, and size of respirator for which each employee has been trained and fit tested.

Program Evaluation

Subcontractors must conduct periodic evaluations of the workplace to ensure that the provisions of this program are being implemented. The evaluation will include regular consultations with employees who use respirators and their supervisors, site inspections, air monitoring and review of records.

Identified problems will be noted and addressed by the Subcontractor. These findings will be reported to LGC, and the report will list plans to correct deficiencies in the respirator program and target dates for the implementations of those corrections.

Documentation and Recordkeeping

A written copy of this program and the OSHA standard is kept at the Subcontractor's office and must be available to all employees who wish to review it.

Also maintained in the Subcontractor's office are copies of training and fit test records. These records will be updated as new employees are trained, as existing employees receive refresher training, and as new fit tests are conducted.

The Subcontractor must also maintain copies of the medical records for all employees covered under the respirator program. The completed medical questionnaire and the physician's documented findings are confidential and will remain at the Clinic where initial testing was completed. The company will only retain the physician's written recommendation regarding each employee's ability to wear a respirator.

RIGGING

INTRODUCTION

Lucas General Contracting recognizes the inherent risk associated with rigging, lifting and hoisting materials, equipment and supplies. The following policies are provided to help insure that operations involving hoisting and the application of ropes, slings, chains and accessories are done safely. This Safety Manual is not intended to replace the required training on Rigging and Hoisting.

ACCOUNTABILITY

Superintendent

The LGC Superintendent and the Subcontractor's Foreman must collaborate on the anticipated risks associated with rigging and crane usage for each project. Each project is unique in design and may require a specific rigging and lifting plan.

Subcontractor and Vendors are responsible for ensuring that all rigging operations are conducted by qualified riggers in accordance with standard procedures provided herein.

The Subcontractor's Foreman must ensure that:

- Appropriate rigging equipment is serviceable and made available.
- Inspection of all rigging equipment prior to each use. Load rating marks or tags must be visible.
- Load ratings are appropriate for the application.
- Proper rigging of the load and application of the rigging equipment
- Safety of the rigging crew and other personnel affected by the rigging operation.
- No loads shall be picked and/or flown using the banding straps, bundle wire or tie wire. Exception: a load may be lifted using banding straps or bundle wire no higher than necessary to insert chokers and or dunnage*.
- Fabrication Shops may pick and fly stock bundles of rebar using the bundle tie wire placed at the mill. All picks by bundle wire must have the safety chains installed.
- Please instruct crane operators to use extreme caution when picking any load by tie wire.
- If it is possible to use the safety chains on any load then the operator must use them.
- Loads picked solely by tie wire may never be flown over or above any one at any time.

RIGGING BEST PRACTICES

General Rigging Procedures and Precautions

1. Know the safe working load of the equipment and tackle being used. NEVER exceed this limit.
2. Determine the weight of the load before rigging it.
3. Examine all hardware, equipment, tackle and slings before use. Have any defective components removed immediately!
4. If you think equipment or rigging is unsafe, do not use it and report the issue to the appropriate authority immediately.
5. Never carry out rigging or hoisting operations if weather creates a hazard to personnel, equipment, property or the public. No hoisting or crane usage is authorized when winds exceed 20 knots.
6. Do not conduct rigging and lifting operations whenever the temperature is below freezing (32 degrees F).
7. Rigging and lifting is not allowed within 20' of overhead power-lines.

8. The load must always be kept below the boom point or upper load block. Side loading reduces stability and introduces stresses for which the equipment is not designed.
9. The weight of the hook blocks, hooks, slings, equalizer beams, material handling equipment, etc. must be taken into account in determining the maximum allowable load you can handle.

Chain

1. Only alloy steel chain (stamped with an “A” on each link) assembly with rated tags applicable to the configuration will be used for hoisting purposes.
2. Modified chains or chain assemblies without tags are not authorized for use.
3. Damaged or shock loaded chains must be removed from service.
4. Twists or knots in a chain are not allowed at any time.

Wire Rope

1. The safe working load for wire rope shall not be exceeded.
2. Wire rope clips shall not be used to form eyes or to make wire rope splices.
3. Wire rope with one or more of the following defects will be removed and replaced:
 - A. **Corrosion:** Corrosion may result from acids or alkalis. Rust film which has not resulted in pitting or loss of the original individual wire diameter should be removed and the rope lubricated.
 - B. **Broken Wire:** One or more valley breaks. (A valley break is an individual wire break occurring in the valley between two adjacent strands.)
4. Six randomly broken wires in one wire rope lay or three wires in one lay:
 - A. **Abrasion:** Abrasion, scrubbing, flattening resulting in loss of more than one-third the original diameter of the outside wires.
 - B. **Kinking:** Kinking, crushing, bird caging, or other damage resulting in distortion of the rope structure.
 - C. **Heat Damage:** Evidence of heat damage resulting from a torch, excessive friction, or contact with electrical wires.
 - D. **Reduction in diameter.** Reductions from nominal diameter of more than 3/64 inch for rope diameters up to and including 3/4 inch, or more than 1/16 inch for diameter 7/8 to 1-1/8 inches, and of more than 3/32 inch for rope diameters 1-1/4 to 1-1/2 inches.
5. If one or more broken wires or corrosion are found adjacent to a socket or end fitting, the wire rope will be removed from service.
6. Defective wire rope should be cut up and discarded or painted “safety orange” or “safety red” to identify it as defective.

Slings

1. Synthetic web slings have wear indicators (usually red threads embedded in the fabric.) Slings must be inspected as per the manufacturer’s recommendations. Discard the sling when the wear indicators begin to show. Discard cut or frayed synthetic slings.
2. Use softeners and wraps to prevent severe wearing from rough concrete surfaces or sharp metal.
3. Synthetic web slings are sensitive to fumes, vapors, sprays, mists or liquids of acids or phenolic. Avoid exposure to any of these.
4. Whenever having wire rope slings made up, get a Flemish eye with pressed metal sleeve and a thimble. The thimble prevents crushing and abnormal wear.
5. Synthetic slings must be kept out of the sun when not in use.

Hardware (Shackles, Hooks, Links, Eye Bolt, Rings, Swivels, Spreader Bars)

- 1) All hardware must be inspected prior to each use. Signs of wear include but are not limited to:
 - Wear marks
 - Cracks
 - Corrosion
 - Deformation/bending
 - Mismatched parts
 - Obvious damage
 - Broken or missing latch
- 2) Avoid shock loading, dragging, modifying or altering hardware.
- 3) Screw Pin Shackles-The screw pin will be fully seated with the shoulder in contact with the body (cotter keyed if applicable).
- 4) Multiple slings on hooks, shackles or rings shall not exceed 120 degrees included angle.
- 5) Hooks shall have a working latch and shall not be side, tip, or back loaded.
- 6) Sorting Hooks shall not be tip loaded or deformed in any way.
- 7) Spreader Bar rating must be clearly marked in a visible location.

Load Control

- 1) Balanced loads are the key to controlling the lift.
- 2) Pick points should be from the end 2 1/2 inches for every foot of load length.
- 3) Hooks at the load should be faced outward.
- 4) Corners reduce capacity and should be padded and or guarded.
- 5) Multiple pick points on a spreader bar should be well balanced.
- 6) Tag Lines are required for landing the load.
- 7) The signal person shall not position themselves under the crane or in a pinch point.

INSPECTION OF FITTINGS WIRE ROPE TERMINATIONS



MORE THAN ONE BROKEN WIRE AT ANY
(WITHIN ONE WIRE ROPE DIAMETER OF THE
FITTING) TERMINATION IS CAUSE FOR REMOVAL
FROM SERVICE

(POH44)

WIRE ROPE CLIPS ADDITIONAL CRITERIA



(POH70AA)

WEDGE SOCKETS ADDITIONAL CRITERIA

LIVE LINE IN-LINE WITH PIN

PROPER TAIL LENGTH (6 to 8 strand wire rop):
AT LEAST 6 DIAMETERS, NOT LESS THAN 6"

PROPER TAIL LENGTH (rotation resistat wire rop):
AT LEAST 20 DIAMETERS, NOT LESS THAN 6"

PROPERLY SECURED TAIL,
DO NOT "CLIP" TO LIVE LINE



(POH85AA)

INSPECTION RECORDS WIRE ROPE SLINGS

INITIAL:
WRITTEN RECORDS NOT REQUIRED

FREQUENT:
WRITTEN RECORDS NOT REQUIRED

THE PERIODIC INSPECTION :
WRITTEN RECORDS OF THE MOST RECENT PERIODIC INSPECTION SHALL BE MAINTAINED AND SHALL INCLUDE THE CONDITION OF THE SLING.

(POH191)

ASME B30.9 - 2003

INSPECTION OF WIRE ROPE SLINGS REMOVAL CRITERIA

MISSING OR ILLEGIBLE SLING IDENTIFICATION

EXCESSIVE BROKEN WIRES

SEVERE LOCALIZED ABRASION OR SCRAPING

KINKING, CRUSHING, BIRDCAGING, OR ANY OTHER DAMAGE RESULTING IN DAMAGE TO THE ROPE STRUCTURE

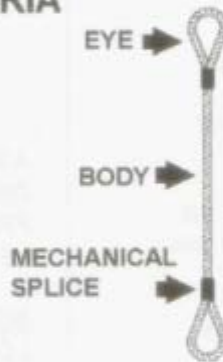

(POH511AA)

ASME B30.9 - 2003

INSPECTION OF WIRE ROPE SLINGS REMOVAL CRITERIA

EVIDENCE OF HEAT DAMAGE

END ATTACHMENTS THAT ARE CRACKED, DEFORMED, OR WORN

SEVERE CORROSION OF THE ROPE, END ATTACHMENTS, OR FITTINGS

OTHER CONDITIONS, INCLUDING VISIBLE DAMAGE, THAT CAUSE DOUBT AS TO THE CONTINUED USE OF THE SLING



(POH511AB)

ASME B30.9 - 2003

INSPECTION OF WIRE ROPE SLINGS KINKING

KINKING IS CAUSE FOR REMOVAL FROM SERVICE



INSPECTION OF WIRE ROPE SLINGS BROKEN WIRES

STRAND LAID AND SINGLE PART SLINGS

10 RANDOMLY BROKEN WIRES IN ONE ROPE LAY, OR 5 WIRES IN ONE STRAND IN ONE ROPE LAY IS CAUSE FOR REMOVAL



INSPECTION OF WIRE ROPE SLINGS DOGLEG

LOOK FOR DISPLACED STRAND, IF A STRAND IS SIGNIFICANTLY DISLOCATED, REMOVE FROM SERVICE

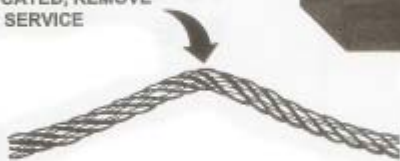

CABLE LAID AND BRAIDED SLINGS CAUSE FOR REMOVAL

SLING BODY	BROKEN WIRES CAUSE FOR REMOVAL
6 PART BRAID	20 PER BRAID LENGTH
8 PART BRAID	40 PER BRAID LENGTH
CABLE LAID	20 PER LAY LENGTH

WIRE ROPE SLINGS TEMPERATURE



STEEL CORE SLINGS
-60°F (-51°C) TO
400°F (204°C)



FIBER CORE SLINGS
-60°F (-51°C) TO
180°F (82°C)

INSPECTION OF WIRE ROPE SLINGS SEVERE WEAR, ABRASION OR SCRAPING



METAL LOSS OF 1/3 OF THE DIAMETER OF THE INDIVIDUAL OUTSIDE WIRES IS CAUSE FOR REMOVAL

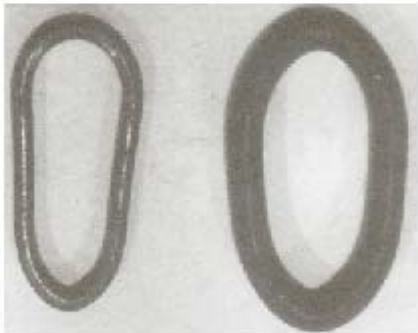
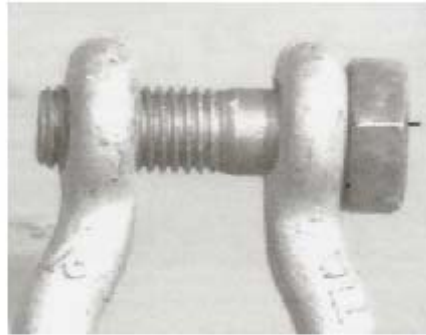

Note Allowed:

- Damaged or modified lift eyes.

Not Allowed:

-Bent damaged or modified shackles.

-Shackles must have original pin & cotter key if required.

Not Allowed:

-Damaged or deformed lift links.

-Bent damaged or modified hooks.

-Hooks with damaged or missing latches.

-Hooks with cracks and wear marks.

WELDING AND CUTTING SAFETY

Oxygen/Acetylene Safety Rules

1. Cylinders must be stored and used in an upright position.
2. Cylinders must be secured from falling.
3. Keep all sources of ignition at least 20 feet away from storage area.
4. Oxygen and acetylene cylinders must be stored separately (at least 20 feet apart or by a non-combustible barrier 5 feet high).
5. A 10lb ABC fire extinguisher must be with the torch head and not on the cart while welding and cutting.
6. Never store cylinders in the same area as oil, grease or other petroleum products. **CONTACT BETWEEN OXYGEN AND ANY PETROLEUM BASED PRODUCT CAN RESULT IN FIRE AND/OR EXPLOSION.**
7. Always attach the valve protection cap when the cylinder is not being used. (The cap is designed to protect the valve from damage.)
8. Make sure all cylinders are clearly marked with their contents. (i.e.) oxygen, acetylene, etc.
9. When a cylinder has been emptied, mark it "empty", or "M.T."
10. When opening a valve from a cylinder, stand to one side - not directly in front.
11. Prior to opening the valve, back the regulator pressure adjustment screws all the way off so that no pressure is allowed to enter the hose. Once the valve is open, slowly adjust the regulator pressure to the desired setting. **NOTE: Normal working pressure for oxygen is 40 lbs. Normal working pressure for acetylene is 15 lbs. NEVER EXCEED 15 LBS. WORKING PRESSURE ON ACETYLENE!!** It is not stable beyond 15 lbs.
12. Do not use an oxygen/acetylene hose which has been damaged and/or is leaking.
13. Make sure that hoses are not placed where they can be walked on, driven over, cut or otherwise damaged.
14. All welding gas hoses must conform to the following approved color chart:
 - Green - Oxygen
 - Red - Acetylene
 - Black - Air/inert gas

Electric Arc Welding Equipment Safety Rules

1. Check both the weld lead cable and the work lead cable for damaged insulation and for exposed wires.
2. Check electrode holders for loose or exposed connections..
3. Do not coil the electrode cable around your body.
4. Check the composition of fluxes, rods and coating. If there is a potential hazard, find out how to protect yourself (read MSDS).
5. Ground both the frame of the welding equipment and the metal being welded. Do not attach the ground wires to pipes carrying gas or flammable liquids or to metal conduits carrying electrical wires. Ground as close to the machine as possible.
6. When floors are wet take precautions against shock.
7. Do not allow metal parts in contact with the electrode to touch your skin or wet clothing. Wear dry work gloves.
8. Do not cool electrode holders by putting them in water.
9. Electrically disconnect the welding equipment when changing electrodes in gas tungsten arc electrode holders.

Personal Protective Equipment

Personal protective gear for welders is required to protect the operator's eyes from radiation and to protect the operator from hot weld slag.

1. Sunglasses or colored glass will not provide sufficient protection against radiation. Specially designed helmets equipped with filter plates- to protect against ultraviolet, infrared and visible radiation must be worn when arc welding. (minimum shade #10).
2. Cover bare skin to protect against both sparks and radiation.
3. Clothing should be free of grease and oil and other substances which may burn.
4. Do not wear clothing with cuffs or pockets where sparks can lodge. Flameproof gauntlet gloves, a leather, or asbestos apron and high top shoes provide good protection against sparks and hot slag.
5. If the work being welded is located in an area where hard hats are required, ensure that your welding hood is adaptable to your hard hat.
6. If others are working in the area where you are welding, install curtains or other means of "flash" protection prior to welding.

Safe Welding Procedures - Fire Prevention

1. Never begin welding tasks until you have obtained adequate fire protection. Do not allow welding in areas which have not been made fire safe.
2. Clear the area of paper, wood shavings and other flammable materials for a space of 35 feet. Move other flammable materials at least 35 feet from the work area or cover them with fire resistant shields.
3. Cover the cracks and openings in the floor to prevent sparks from falling through to the lower floors. If it isn't possible to do this, check the lower floor and make sure there are no combustibles which could be exposed to sparks.
4. When possible move the work to be welded to a safe location.
5. Cover wooden floors with a fire resistant material.
6. Cover nearby combustible walls and partitions with fire resistant shields. If the walls are made of metal, remove the combustible material from the other side. If they cannot be removed, station a "fire watch."
7. Maintain a "fire watch" during the work and for 1/2 hour after the work is completed.
8. Train "fire watchers" in the proper use of fire extinguishing equipment and how to sound alarms.
9. When hazardous substances are used as base metals, fluxes, plating or filler metals, local exhaust ventilation must be used. Beryllium, cadmium, chromium, fluorides, lead, mercury, zinc or any inert gas metal arc welding, and oxygen cutting of stainless steel, all require the use of local exhaust ventilation to bring toxic concentrations within the Permissible Exposure Limit (PEL). If it is not possible to supply adequate ventilation, use a respirator (see the respiratory protection program).

SECTION IV

PRE-PLANNING POLICIES

COLUMN & WALL ERECTION POLICY

INTRODUCTION

Lucas General Contracting recognizes that the erection of rebar columns and walls can pose serious risks to those individuals who work on or around them. The variety of activities associated with column or wall erection, including, hoisting, connecting, supporting, and adjusting, can all contribute to workplace accidents, and it is the goal of Lucas General Contracting to ensure that these job activities are done in a safe manner. This policy establishes Lucas General Contracting guidelines that it expects its Subcontractors will follow the erection of rebar columns and walls.

ACCOUNTABILITY

The Subcontractor's Foreman is responsible for the safe erection of columns and walls and is responsible for collaborating with his company to ensure the proper materials and equipment will be provided on the jobsite.

APPLICATION

PRE-PLANNING

A pre-planning meeting shall take place between the LGC Field Superintendent and Subcontractor's Supervisor. This meeting shall take place prior to any column or wall erection activity. It shall cover the column support plan, and recommendations to LGC to ensure a safe jobsite. If applicable, the column guy plan shall be provided by the Subcontractor and reviewed by LGC.

The Subcontractor's Foremen is responsible for completing a Vertical Erection Plan, VEP, and submitting the plan to LGC prior to standing and rebar structures. A jobsite meeting shall take place between the LGC Subcontractor's Foreman and the crew working on the job. The tailgate meeting shall cover: 1) column safety and 2) column and wall support plan 3) guying procedures 4) spacing and a review of the VEP. This shall be documented by the Subcontractor's Foreman. (Tailgates Provided)

CRANES & RIGGING

The crane and rigging guidelines detailed in their respective sections are a critical element of this erection policy and must be adhered to.

COLUMN SUPPORTS

During the pre-planning meeting, the column support plan shall be addressed. This also includes a support plan for walls, column/wall supports include guy cables, and pipe braces.

Walls: shall be rigged according to the applicable section of this manual, and shall be supported by a crane until the appropriate ties have been completed. The Foreman shall clear the area at the base of the wall prior to releasing the load.

Columns: which pose a falling hazard, (as determined by the size, weight, length) shall be supported with one or a combination of the following: (Whichever is more secure)

- 4 to 8 Guy Cables (dependent on column size)
- Continuous Crane Support
- At least 2 pipe braces (90 degree angles) unless an approved site specific Vertical Erection Plan calls for more bracing.
- Horizontal Bracing (cloths-lining) (Horizontal Bracing shall not be used as the sole support of columns)

Guy Cables:

- Must be 3/8, with cable clamps secured using the appropriate method described in the rigging section of this manual.
- Guy cables shall have flags or warning devices, to ensure that these supports are visible to all employees on site.
- Dead-men, with guy cables attached, shall be of suitable size and weight, and strategically located, to provide proper support.

Pipe Braces:

- Pipe braces shall be painted with a bright color, to ensure they are visible to all employees.
- A missing, defective or inappropriate pipe brace shall be brought to the attention of the jobsite Foreman immediately.
- A missing, defective or inappropriate guy cable/pipe brace not suited for the job shall be brought to the attention of the jobsite foreman immediately.
- At no time, shall any pipe brace or guy cable be removed or adjusted without approval from the jobsite foreman. In no event shall the Subcontractor deviate from an engineered column guy plan, without prior written approval from the Design Engineer.
- Pipe braces shall be securely anchored to the column and the deck or ground.

COMMUNICATION

LGC shall make every effort to inform the Subcontractor of the importance of column safety. It is everyone's responsibility on a construction jobsite to notify supervisors of any unsafe condition.

In the event of an identified hazard, LGC and its Subcontractors will follow these steps:

1. Foreman must verbally notify LGC Superintendent of safety concern and request an immediate response.
2. If the situation is not resolved to the Foreman's satisfaction, notify the Director of Safety.
3. The Field Superintendent will evaluate the hazard, and place the proper Subcontractor on notice.
4. If imminent safety hazard exists the Foreman is required to stop work and remove personnel from the work-zone until the hazard is removed.

COLUMN & WALL SAFETY

Falling columns are one of the leading jobsite hazards for rebar contractors. A falling column can kill you or your co-worker in a split second. You may not have the time to react to a falling column, but, you do have PLENTY OF TIME to properly support columns/walls to avoid any accident from occurring.

REVIEW OF COLUMN & WALL SUPPORT PLAN WITH CREW

- Daily inspection of pipe braces, cable clamps, rigging, wenches, etc. used in charging/pulling/bracing. Destroy any damaged/badly worn equipment.
- At no time shall a pipe brace be removed or adjusted on a column cage without proper supports. All vertical elements shall be properly supported to prevent collapse either through use of internal or external support(s). Prior to any employee climbing any vertical elements (e.g. walls or columns), the same shall be supported via the use of external supports such as guy wires or pipe braces.
- Guy cables shall be at least 3/8", and shall have flags or warning devices.
- Pipe braces shall be spaced at 90 degree angles from each other.
- Pipe braces shall be painted with a bright color to ensure supports are visible to employees on site.
- Always use a crane for support if there is any uncertainty of column stability.
- Check your ties before picking.
- Public concerns must be evaluated when erecting, i.e. near pedestrian walks, areas of vehicular traffic and high winds.

CRANE SAFTEY PRECAUTIONS

1. Check load limits.
2. Crane will not be left unattended with a load suspended.
3. One signaler shall be designated to direct the operator when the point of operation is not in direct view of the operator. The signaler must make sure that all Riggers report "All Clear" before any crane movements are made.
4. Loads shall not be swung over any personnel and no one shall work under a suspended load. If there is no other means, safety type hooks must be used when loads pass over workers.
5. When guiding loads, use a tag line or hook. If you have to walk a load, keep it as close to the ground as possible.
6. A Critical Lift checklist will be completed by the Subcontractor's Foreman anytime: 2 cranes are used; a lift is within 75% of load chart, any unusual conditions exist.
7. Suspended loads must be kept clear of all obstructions.
8. Crane Operator shall ensure a visual barrier shall surround the perimeter of the crane. Use flags or caution tape.
9. Crane shall not be operated such that any machine part or load will come within 20 feet of electrical lines.

JOB SAFETY ANALYSIS

INTRODUCTION

The Job Safety Analysis Program is defined as a task driven document to ensure that every job task receives proper safety planning prior to beginning work.

A job safety analysis is to be developed for all high risk tasks and operations.

ACCOUNTABILITY

The Subcontractor's Foreman is responsible for the completion of the required JSA reflecting work performed on the specific jobsite. Workers shall be trained in the hazards associated with performing the task.

APPLICATION

The JSA process can be completed on the form provided or a form required by the controlling entity.

LUCAS GENERAL CONTRACTING	Job:	Date:
	Title of Person Who Does Job:	Analysis By:
Department: EXAMPLE		Reviewed: Safety Office Review:
Required Recommended PPE: Eye protection, Hard hat		
Job Steps	Hazards	Safety Procedures
Shake out iron	Strains, hand and finger injuries	Observe careful hand placement Use proper lifting techniques – lift with legs, back straight
Punk iron to work area	Strains, slip, trip and falls	Use proper lifting techniques – lift with legs, back straight 2 man carry – carry the bar on the same shoulder Watch foot placement while walking
Install long bars	Strains, hand and finger injuries	Careful hand placement Proper lifting techniques
Install chairs	hand and finger injuries	Observe careful hand placement
Tie chairs	hand and finger injuries, wire pokes	Observe careful hand placement
Mark profile and tie support bars	hand and finger injuries, wire pokes	Observe careful hand placement
Pull cage into the hole	Strains, hand and finger injuries, slip, trip and falls	Use proper lifting techniques, Watch foot placement while walking, Observe careful hand placement Coordinate communication with crew prior to moving cage into place

SECTION V

OCCUPATIONAL HEALTH

BLOODBORNE PATHOGEN EXPOSURE CONTROL PLAN

INTRODUCTION

Bloodborne Pathogens can represent a significant exposure to workers who come in contact with infectious materials. The following policy applies to all LGC and Subcontractor employees who have been assigned duties to render first aid treatment to injured co-workers on the job. It also applies to those employees who are responsible for the clean-up of areas where a job-related injury involving blood or other potentially infectious material is present.

RESPONSIBILITIES

The Superintendents have the responsibility to ensure that no workers are exposed to blood, saliva, or any other body fluids or emissions that may be present after incident or accident.

Employees involved in an “exposure” to potentially infectious material should contact their Foreman or Supervisor. Any employee who has been exposed to potentially infectious material shall be offered the Hepatitis Vaccine at no cost to the employee.

First Responders are offered the Hepatitis Vaccine when first assigned First Responder duties and whenever an exposure event occurs.

Exposure Control Plan Best Practices

- All materials used in the treatment of an injury, which are contaminated with blood or other potentially infectious material, shall not be disposed of in trash receptacles. This material (latex gloves, contaminated sponges, etc.) shall be placed in the Bio-Medical disposal bags that are kept in the first-aid kit. These bags shall be transported to a nearby hospital for disposal.
- Tools, clothing, counter tops or any area contaminated by blood or other potentially infectious material shall be thoroughly cleaned with a 1:10 solution of bleach, then washed with soap and water. Materials contaminated by this clean-up process shall be placed in Bio-Medical bags for disposal.
- Any employee involved in the clean-up following an incident involving blood or other potentially infectious material shall wear, at a minimum, latex gloves and safety glasses as a protection from Bloodborne pathogens.

FIRST AID PROGRAM

Introduction

First aid is emergency care provided for injury or sudden illness before emergency medical treatment is available. The first-aid provider in the workplace is someone who is trained in the delivery of initial medical emergency procedures, using a limited amount of equipment to perform a primary assessment and intervention while awaiting arrival of emergency medical service (EMS) personnel.

A workplace first-aid program is part of a comprehensive safety and health management system that includes the following four essential elements:

- _ Management Leadership and Employee Involvement
- _ Worksite Analysis
- _ Hazard Prevention and Control
- _ Safety and Health Training

OSHA Regulations

Sudden injuries or illnesses, some of which may be life-threatening, occur at work. The OSHA First Aid standard (29 CFR 1910.151) requires trained first-aid providers at all workplaces of any size if there is no “infirmary, clinic, or hospital in near proximity to the workplace which is used for the treatment of all injured employees.”

In addition to first-aid requirements of 29 CFR 1910.151, several OSHA standards also require training in cardiopulmonary resuscitation (CPR) because sudden cardiac arrest from asphyxiation, electrocution, or exertion may occur.

If an employee is expected to render first aid as part of his or her job duties, the employee is covered by the requirements of the Occupational Exposure to Bloodborne Pathogens standard (29 CFR 1910.1030). This standard includes specific training requirements.

Responsibilities

All Superintendents are required to take and maintain a current First Aid / CPR certification. Training is provided through company trainers and/or nationally recognized training organizations.

First Responders have been identified by the Director of Safety. First Responders are also provided First Aid / CPR training and required to retrain every 2 years.

All employees are trained annually in Bloodborne Pathogens Awareness through tailgate meetings.

First Aid Supplies

First aid supplies are stored in the following locations:

- Superintendents & Foremen’s trucks
- Job site offices and storage bins
- Offices

Sufficient First Aid Supplies are stocked at each of the above locations to accommodate crew size and in accordance with the minimum requirements per OSHA Regulations.

Clinics

Through a network of approved clinics every jobsite location should assign the nearest available clinic for emergency treatment of injured employees and post the phone number and address on the safety poster on the designated spot. Employees needing care beyond the scope of industrial clinics are referred to Hospital Emergency Rooms.

First Responder Duties

First Aid is the initial emergency care given immediately upon arrival at the scene to an ill or injured person and continues until professional medical assistance takes over the care of the casualty (such as an ambulance EMT, Police Officer or Doctor).

A first responder's role is to:

- Preserve life.
- Protect the unconscious casualty.
- Prevent the condition worsening.
- Promote recovery.
- Call for medical assistance.

Priorities in an Emergency

In all emergency situations, the first responder must:

- Ensure the safety of themselves, any bystanders and the casualty(s)
- Assess the situation quickly.
- Call for help (911).
- Commence appropriate treatment within limits of their abilities.
- Closely monitor the casualty for changes in condition

Precautions to be taken:

- Wash your hands before and after treatment.
- Use disposable gloves when treating a casualty.
- Change gloves before treating a different casualty.
- Use protective aprons and eye protection where available.
- Cover any open cuts you may have with waterproof dressings.
- Wash off any body fluids immediately.
- Dispose of used gloves and contaminated waste correctly.
- Wash re-usable equipment in an anti-bacterial solution
- Use protective masks with a one-way valve and/or viral filter when performing Rescue Breathing.

Site Specific Instruction

- First responders must be familiar with the EAP (Emergency Action Plan) at their job site location.
- When the decision is made to evacuate the building or job site, First responders will collect emergency supplies, and/or first aid kit, prior to evacuation.
- First responders will make a final sweep through the building or job site as they are exiting the building to ensure that all personnel have evacuated.

***Note.** First responders must never attempt to re-enter a building or job site following an evacuation until Management or Emergency Personnel say it is safe to re-enter.

HAZARD COMMUNICATION PROGRAM

INTRODUCTION

The purpose of this notice is to inform you that Lucas General Contracting is complying with the OSHA Hazard Communication Standard, Title 29 Code of Federal Regulations 1910.1200, by compiling a hazardous chemical list, by using MSDSs, by ensuring that containers are labeled, and by providing you with training.

Lucas General Contracting respects an employees' right to know about the hazards associated with chemicals in their workplace. The Hazard Communication Program will provide employees with information about hazardous chemicals in the workplace.

Proposition 65 requires the governor to publish a list of chemicals known to the State of California to cause cancer, birth defects, or reproductive harm. Proposition 65 also requires that businesses provide a clear and reasonable warning before knowingly and intentionally exposing anyone to a listed chemical. Compliance with Proposition 65 requirements for notifying employees of hazards can be achieved simply by complying with the provisions of California's hazard communication regulation.

MSDS's provide you with specific information on the chemicals you use. The Director of Safety maintains a complete list of hazardous chemicals used on LGC job sites. The MSDS will be a fully completed OSHA Form 174 or equivalent. If you have any questions regarding chemicals at the jobsite, use the MSDS or contact the Director of Safety.

ACCOUNTABILITY

Superintendent

The office must compile and maintain a list of all hazardous chemicals that will be used on their jobsites. The list will be updated as contracts are issued.

The Superintendent will notify workers of the hazards associated with chemicals in use at the job-site. A Material Safety Data Sheet shall be kept in the foreman's manual in the construction office and made available to all workers upon request. The Superintendent should also ensure no unauthorized chemicals are introduced to the work-zone and no other trades expose their workers to chemicals.

Note: Only the MSDS for the chemicals on site should be kept in the jobsite notebook.

HAZCOM BEST PRACTICES

LABELING

Each container of chemicals or hazardous material on the jobsite shall be properly labeled. Damaged and or illegible labels should result in discarding the material in the appropriate manner.

MATERIAL SAFETY DATA SHEETS

Copies of MSDS Sheets for all hazardous chemicals to which employees may be exposed are kept in a MSDS binder or file at each jobsite and are readily accessible to employees.

EMPLOYEE TRAINING

Lucas General Contracting employees do not typically come in contact with hazardous chemicals or materials in the course of their work. A tailgate safety Meeting should be held for all new employees to discuss any chemicals or materials they will be working with or may be exposed to.

Hazardous Materials Management Program

Emergency Contact Information:

Rob Plavajka – 949/474.0221
1111 Quail Street
Newport Beach, CA 92660
714/307.9336 Cell

Robert Mahony 949/474.0221
1111 Quail Street
Newport Beach, CA 92660
714/299.4636 Cell

Emergency Response

In the event a Subcontractor or vendor experiences an accidental release on a LGC project they will be required to provide emergency containment systems to control the release. The Subcontractor or vendor will also be required to report the release to appropriate authorities. LGC does not allow any one chemical in quantities in excess of 50 gallons and will maintain a spill kit for containment of 50 gallons in the event of an accidental release.

MSDS

Material Safety Data Sheets will be provided with each chemical used on the project site and cross referenced with the MSDS on file. MSDS will be maintained with hard copies when required.

Labeling

All chemical containers of any size or shape shall have the manufacturers label in legible condition affixed to the outside of the container. Any container that is damaged, leaking or rusted must be repackaged or disposed of as a recyclable. Labels that become illegible must be replaced with temporary labels providing the same information that was originally on the containers.

Storage

Chemicals

No waste chemicals or residual product that will not be used within a 30 day period are allowed to be stored at any LGC projects. New chemicals in original packages may be stored in quantities less than 50 gallons. The cumulative total of any one chemical may not exceed 50 gallons.

Flammable Materials will be stored in approved storage containment systems, separate from combustibles, gases or caustics.

Compressed Gas Cylinders

Compressed gas cylinders will be stored as required in the LGC Safety Plan; segregated and secured. At no time will a LGC project store more than 200 cubic feet of a flammable compressed gas or oxidizer.

Whenever possible compressed gas will be stored outside of the facility in a specified location with the appropriate placards outside of the facility.

Vehicle/Forklift Maintenance

Vehicles and mobile equipment are outsourced, with no waste products being generated on LGC projects. Lubricating fluid and associated filters and containers are provided by a contracted service and all waste is accumulated and recycled by the vendor/Subcontractor.

Permit Requirements

The State of California requires the issuance of an EPA ID number for all generators of any amount of Hazardous Waste. The permit requirements can be found at the following website: www.dtsc.ca.gov . Permits will be maintained at the facility registered under the permit. Each county where LGC has a project may require the issuance of an additional permit through the county Hazardous Materials Program.

Responsibility

Each LGC and Subcontractor employee has a responsibility to adhere to the HAZMAT program and best practices identified in the LGC Safety Manual and those indicated on the MSDS.

Overall responsibility for the Lucas General Contracting Hazardous Material Program lies with the Director of Safety and jobsite Superintendent.

SECTION VI

APPENDICES

- A. Notice of Violation Report**
- B. Near Miss Report**
- C. Report Of Accident – Personal Injury**
- D. Medical Treatment Waiver**
- E. Hepatitis B Vaccination Consent/Waiver Form**
- F. Liability Report**
- G. Report of Property Damage**
- H. Auto Accident Report**
- I. Accident Reporting - OSHA Contact Information**



NOTICE OF VIOLATION

Project site: _____ Project #: _____

Time of Violation: _____ Date: _____

Superintendent: _____

Subcontractor: _____

Subcontractor
Employee: _____

Describe The Violation:

Corrective/Disciplinary Action: _____ Date of Correction _____

Subcontractor Employee Signature: _____

Subcontractor Supervisor Signature: _____

Issued by: _____



NEAR-MISS REPORT

PLEASE EMAIL OR FAX THIS FORM TO THE DIRECTOR OF SAFETY WITHIN 24 HOURS OF THE INCIDENT
Email: RPLAVAJKA@LUCASCOMPANIES.NET Fax: (949) 474-3097

Project: _____	Vendor: _____
Superintendent: _____	Supplier: _____
Subcontractor: _____	Employee: _____
Date of Incident: _____	Time of Incident: _____

Incident: _____

Root Cause Analysis: _____

Corrective Action: _____

Correction Action Completed: Yes No **Date Completed:** _____

_____ Subcontractor's Foreman's Signature	_____ Printed Name	_____ Date
_____ Superintendent's Signature	_____ Printed Name	_____ Date



INJURY INCIDENT – NON INJURY

REPORT OF ACCIDENT – PERSONAL INJURY

JOB NAME/NOMBRE DE TRABAJO:		SUBCONTRACTOR:	
FOREMAN/SUPERVISOR:		FOREMAN CONTACT /TELEFONO DE SUPERVISOR:	
EMPLOYEE			
NAME/NOMBRE:		OCCUPATION/OCUPACION:	
HOME ADDRESS/DOMICILIO:			
HOME PHONE/NUMERO DE TELEFONO		SOCIAL SECURITY #	
GENDER ___ Male ___ Female	DATE OF BIRTH: FECHA DE NACIONAMIENTO	DATE OF HIRE (mm/dd/yy)	
EMPLOYEE USUALLY WORKS/EMPLEADO NORMALMENTE TRABAJAN ___ hrs/day ___ days/week ___ total weekly Hrs		___ Apprentice ___ Foreman ___ Journeyman ___ Non Union ___ Shop ___ Driver ___ Non-Field	
INJURY OR ILLNESS			
DATE OF INJURY/FECHA DE INCIDENTE		TIME INJURY OCCURRED :AM :PM	TIME EMPLOYEE STARTED WORK :AM :PM
ADDRESS WHERE EVENT OCCURRED/DIRECCION EN DONDE OCCURIO EL INCIDENTE		DATE EMPLOYEE REPORTED INCIDENT/FECHA QUE EL EMPLEE REPORTO EL INCIDENTE	
WHERE EVENT EXPOSURE OCCURRED / DONDE OCCURIO EL INCIDENTE:		PART OF BODY AFFECTED/PARTE DEL CUERPO QUE FUE AFECTADA	
SPECIFIC INJURY/ILLNESS AND PART OF BODY AFFECTED, MEDICAL DIAGNOSIS, if available, (i.e., laceration on left knee)			
HOW DID THE INJURY OCCUR? DESCRIBE SEQUENCE OF EVENTS. SPECIFY OBJECT WHICH DIRECTLY CAUSED THE INJURY/ILLNESS: (COMO SE PRODUCEN LAS LESIONS)			
OTHERS INJURED? ___ Yes ___ No	NAMES OF WITNESSES:	REFUSE TREATMENT/NO INJURY TO REPORT (TREATMENT NEGARSE / NO A INFORME LESIÓN) INITIALS:	

Subcontractor's Foreman Signature	Printed Name	Date
LGC Superintendent's Signature	Printed Name	Date

PLEASE FAX THIS FORM WITHIN 24 HOURS OF THE INCIDENT TO FAX (949) 474-3097.



MEDICAL TREATMENT WAIVER

Lucas General Contracting is concerned with every employee's well-being and safety. In the event you elect not to seek medical attention, we need to document that Lucas General Contracting has not influenced, in any way, your decision to not seek treatment.

Brief Description of Accident: _____

Employee: _____

Date of Injury: _____

Brief Description of Accident: _____

Brief Description of Injury: _____

My signature confirms that I have voluntarily waived medical care due to the injury indicated above. Should it later be determined that I require medical care, I will consult with my immediate Supervisor prior to seeking treatment, unless immediate care is necessary.

Employee _____ Date _____

Supervisor _____ Date _____

Superintendent _____ Date _____



HEPATITIS B VACCINATION CONSENT/WAIVER FORM

Name (Please Print): _____

Date of Birth: ___/___/___/ Social Security Number: ___ - ___ - ___

A.)Consent for Hepatitis B Vaccine

I, _____ consent to be immunized against hepatitis B. I acknowledge the following:

- 1. I have been informed that I am at risk of acquiring hepatitis B because of the nature of my professional responsibilities.
2. I have read the information sheet that lists the indications, benefits, and presently known side effects of hepatitis B vaccine, have had an opportunity to ask questions, and have had them answered to my satisfaction.
3. I must receive three (3) doses of vaccine over a period of six (6) months to confer optimal immunity.
4. I understand, however, as with all medical treatment, there is no guarantee that I will become immune or that I will not experience an adverse reaction to the vaccine.
5. In the event that I experience any adverse side effects or do not become immune from the vaccine I hereby hold Lucas General Contracting harmless from any and all liability to the extent permitted under the law.
6. In the event that I should terminate employment at Lucas General Contracting prior to receiving all three (3) does of hepatitis B vaccine, I understand that it will be my responsibility to complete the vaccination series on my own initiative and at my own expense.

7. _____
(Employee Signature) (Department) (Date)

Are you currently pregnant or breast feeding? Yes _____ No _____.

Dose/site/Lot#/Initials: _____

C. Refusal to Receive Hepatitis B Vaccine

I, _____, understand that due to my occupational exposure to blood or other potentially infectious materials I may be at risk of acquiring hepatitis B virus (HBV) infection. I have been given the opportunity to be vaccinated with hepatitis B vaccine, at no charge to myself. However, I decline hepatitis B vaccination at this time. I understand that by declining this vaccine I continue to be at risk of acquiring hepatitis B, a serious disease. If in the future I continue to have occupational exposure to blood or other potentially infectious materials and I want to be vaccinated with hepatitis B vaccine, I can receive the vaccination series at no charge to me.

(Employee Signature) (Department) (Date)



LIABILITY REPORT

(PLEASE FULLY COMPLETE AND PRINT CLEARLY)

JOB NAME:		SUBCONTRACTOR:	
SUPERINTENDENT:		JOB PHONE #	
OCCURRENCE/INJURED			
LOCATION OF OCCURRENCE		TYPE OF OCCURRENCE: <input type="checkbox"/> 3 rd Party Liability (Injury/Property Damage) <input type="checkbox"/> Employment Claim <input type="checkbox"/> Other	
ANY WITNESSES? <input type="checkbox"/> Yes <input type="checkbox"/> No		IF YES, INCLUDE NAME & PHONE NO.	
ANY INJURIES? <input type="checkbox"/> Yes <input type="checkbox"/> No		INJURED PARTY ADDRESS & PHONE #	
GENDER <input type="checkbox"/> Male <input type="checkbox"/> Female		INJURED PARTY ADDRESS & PHONE #	
ANY INJURIES? <input type="checkbox"/> Yes <input type="checkbox"/> No		DESCRIBE INJURY:	
INCIDENT/PROPERTY DAMAGED			
DATE OF INCIDENT (mm/dd/yy)	TIME INCIDENT OCCURRED a.m. p.m.		TIME INCIDENT REPORTED a.m. p.m.
ADDRESS WHERE EVENT/EXPOSURE OCCURRED			
DESCRIBE PROPERTY DAMAGED/STOLEN (I.E. FORKLIFT, TOOLS, ETC)			MANUFACTURER AND MODEL NO:
DEPARTMENT WHERE EVENT/EXPOSURE OCCURRED (i.e., field, shop)			On Employer's Premises? <input type="checkbox"/> Yes <input type="checkbox"/> No
ESTIMATE OF PROPERTY DAMAGED/STOLEN:			
OWNER OF PROPERTY DAMAGED/STOLEN:			
SPECIFIC ACTIVITY THE EMPLOYEE WAS PERFORMING WHEN EVENT/EXPOSURE OCCURRED (i.e., unloading truck, welding)			
HOW INCIDENT OCCURRED. DESCRIBE SEQUENCE OF EVENTS. SPECIFY OBJECT OR EXPOSURE, WHICH DIRECTLY CAUSED THE INCIDENT (i.e., sparks from cutting rebar fell and injured 3 rd party pedestrian causing 2 nd degree burns.) USE SEPARATE SHEET IF NECESSARY.			

Subcontractor's Foreman Signature

LGC Superintendent's Signature

Printed Name

Printed Name

Date

Date

Any liability reports shall be immediately reported to Lucas General Contracting. This form must be completed in full and sent to the Director of Safety within 24 hours of incident.

REPORT OF PROPERTY DAMAGE

JOB NAME:		SUBCONTRACTOR:	
SUPERINTENDENT:		JOB PHONE #	
EMPLOYEES/PERSONS INVOLVED			
NAME:		EMPLOYER:	PHONE #
NAME:		EMPLOYER:	PHONE #
NAME:		EMPLOYER:	PHONE #
ANY INJURIES? <input type="checkbox"/> Yes <input type="checkbox"/> No	IF YES, PLEASE ALSO COMPLETE REPORT OF ACCIDENT.		
ANY WITNESSES? <input type="checkbox"/> Yes <input type="checkbox"/> No	IF YES, INCLUDE NAME & PHONE NO.		
PROPERTY DAMAGED			
DATE OF INCIDENT (mm/dd/yy)	TIME INCIDENT OCCURRED a.m. p.m.		TIME INCIDENT REPORTED a.m. p.m.
ADDRESS WHERE EVENT/EXPOSURE OCCURRED			
DESCRIBE PROPERTY DAMAGED/STOLEN (I.E. FORKLIFT, TOOLS, ETC)		MANUFACTURER AND MODEL NO:	
DEPARTMENT WHERE EVENT/EXPOSURE OCCURRED (i.e., field, shop)		On Employer's Premises? <input type="checkbox"/> Yes <input type="checkbox"/> No	
ESTIMATE OF PROPERTY DAMAGED/STOLEN:			
OWNER OF PROPERTY DAMAGED/STOLEN:			
SPECIFIC ACTIVITY THE EMPLOYEE WAS PERFORMING WHEN EVENT/EXPOSURE OCCURRED (i.e., unloading truck, welding)			
HOW INCIDENT OCCURRED. DESCRIBE SEQUENCE OF EVENTS. SPECIFY OBJECT OR EXPOSURE, WHICH DIRECTLY CAUSED THE INCIDENT (i.e., sparks from cutting rebar fell and injured 3 rd party pedestrian causing 2 nd degree burns.) USE SEPARATE SHEET IF NECESSARY.			
POLICE REPORT DEPARTMENT:		POLICE REPORT NO:	

(PLEASE FULLY COMPLETE AND PRINT CLEARLY)

Subcontractor's Foreman Signature	Printed Name	Date
LGC Superintendent's Signature	Printed Name	Date

Any liability reports shall be immediately reported to Lucas General Contracting. This form must be completed in full and sent to the Director of Safety within 24 hours of incident.



AUTO ACCIDENT REPORT

Subcontractor Vehicle

Year: _____ Make: _____
State License Plate #: _____
Serial # _____ (last 6 digits)

Owners Name: _____
Phone: _____
Address: _____

Driver's Name: _____
Phone: _____
Address: _____

Accident Data

Accident Date: _____ Time: _____
Accident Location: _____
City: _____ State: _____
Authority Contacted: _____
Report #: _____

Other Vehicle

Year: _____ Make: _____
State License Plate #: _____
Serial # _____ (last 6 digits)

Owners Name: _____
Phone: _____
Address: _____

Driver's Name: _____
Phone: _____
Address: _____

Driver License #: _____ State: _____
Insurance Co: _____ Policy# _____

Witness

Name: _____ Phone: _____
Address: _____

Name: _____ Phone: _____
Address: _____

Name: _____ Phone: _____
Address: _____

Injured Persons

Name: _____ Phone: _____
Address: _____

Age: _____ Injury: _____

Name: _____ Phone: _____

Address: _____

Age: _____ Injury: _____

ACCIDENT REPORTING - OSHA CONTACT INFORMATION

**For serious injury reporting notify the Director of Safety, if unavailable notify the CFO.
If you are unable to contact a LGC representative call the OSHA office in your area and make the report within
8 hours of the injury.**

Arizona

1-800-321-OSHA (1-800-321-6742).

California:

Concord (925) 602-6517

Foster City (650) 573-3812

Fremont (510)-794-2521

Fresno (559) 445-5302

Los Angeles (213) 576-7451

Modesto (209) 576-6260

Monrovia (626) 256-7913

Oakland (510) 622-2916

Redding (530) 224-4743

Sacramento (916) 263-2800

San Bernardino (909) 383-4321

San Diego (619) 767-2280

San Francisco (415) 972-8670

Santa Ana (714) 558-4451

Santa Rosa (707) 576-2388

Torrance (310) 516-3734

Van Nuys (818) 901-5403

Ventura (805) 654-4581

West Covina (626) 472-0046

Colorado

1-800-321-OSHA (1-800-321-6742).

Hawaii

(808) 586-9102

Idaho

1-800-321-OSHA (1-800-321-6742).

Montana

1-800-321-OSHA (1-800-321-6742).

Nevada

Reno (775) 824-4611

Henderson (702) 486-9029

New Mexico

(505) 476-8700

Oregon

(801) 530-6901

Texas

1-800-321-OSHA (1-800-321-6742).

Utah

1-800-922-2689 or 503-378-3272

Washington

1-800-321-6742.

Federal OSHA toll-free reporting:

1-800-321-OSHA (1-800-321-6742).